

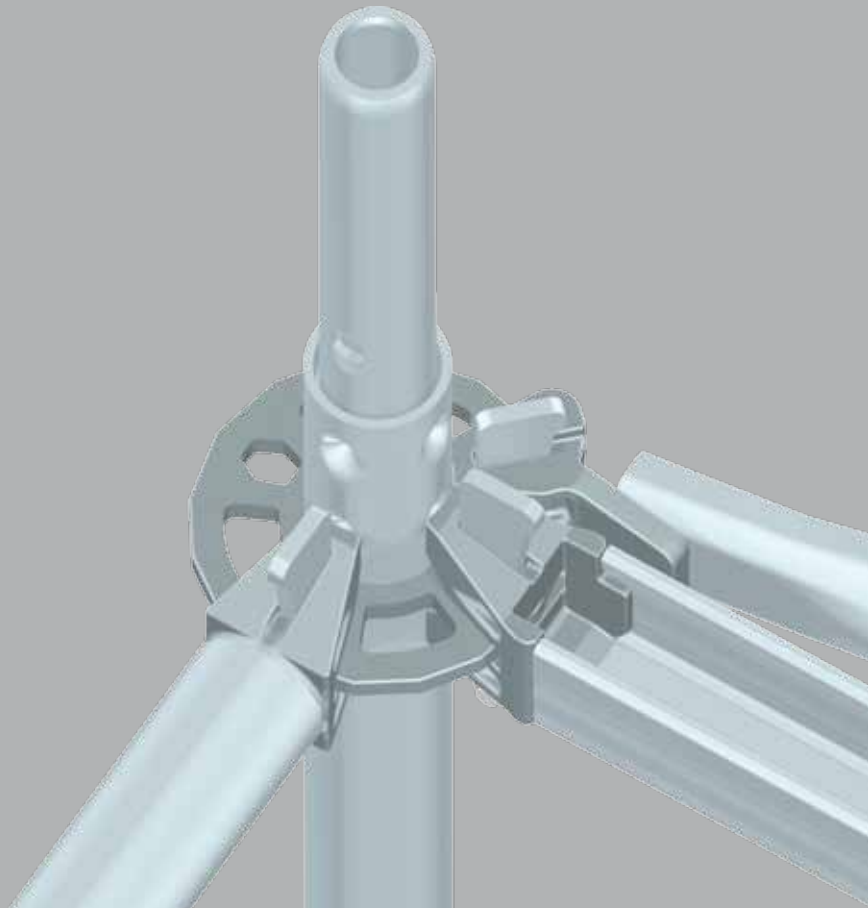

Catalogue and Price List

## ALFIX Modul PLUS II



## ALFIX Scaffolding System Modul Plus II

<b>ALFIX scaffolding connector</b>	p. 2
<b>ALFIX scaffolding system</b>	p. 3

## Price List ALFIX Modul PLUS II

<b>Vertical support elements</b>	p. 4-5
<b>Horizontal support elements / Side protection</b>	p. 6-11
<b>Diagonal bracing</b>	p. 12-13
<b>Scaffolding decks / Hatch-type access decks</b>	p. 14-19
<b>Brackets</b>	p. 20-21
<b>Lattice girders</b>	p. 22-23
<b>Stairways / Ladders / Guardrails</b>	p. 24-29
<b>Accessories</b>	p. 30-31

## Technical Details

<b>Connector forces</b>	p. 32
<b>Loadability of ledgers</b>	p. 33
<b>Cross-section values of base jacks</b>	p. 34
<b>Load classes of scaffolding decks</b>	p. 34
<b>Parameters of horizontal diagonal braces</b>	p. 34
<b>Extracts from the DIN EN 12811 standard</b>	p. 35

The data specified herein is for information only and will not constitute a commercial offer. For contingent misprints in article numbers, article descriptions as well as prices, no liability is assumed. Subject to alterations. All rights remain with the publisher. Any reproduction, either in whole or in part, requires the prior written permission of the publisher.

All prices shall be understood to be net plus statutory VAT. With the publishing of the catalogue on hand, antecedent editions become invalid.

Catalogue and price list ALFIX Modul PLUS II

As of 05/2011

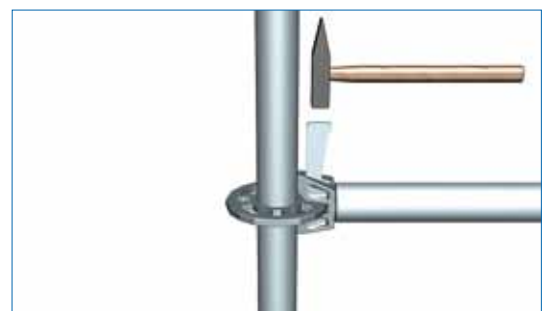
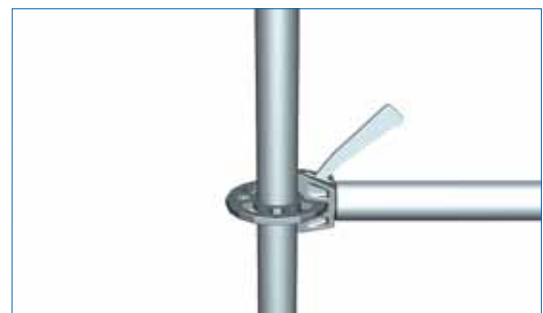
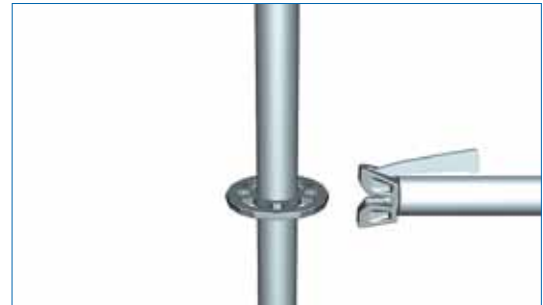

The key element of the "Modul Plus II" system is the ALFIX module connector. The tried and tested wedge lock principle provides for positive and non-positive connectors which are increasingly replacing the time-consuming screwed connections of conventional scaffolding. The ALFIX module connector is located every 50 cm, provides eight connections and can be adjusted in all directions. The connectors' regular metric arrangement every 50 cm allows an almost arbitrary positioning of scaffold platforms at all levels.

Load-bearing capacity and rigidity of connector joints are endorsed by the certificate of approval no. Z-8.22-906. In addition, the system has official building authority approval for combinations (Z-8.22-913), ensuring the compatibility with similar products from other manufacturers.

The "Modul Plus II" modular scaffolding can be used for simple façades, complex industrial structures and sophisticated supporting structures. A maximum of ingenious technology and an easy-to-handle system enable a fast, cost-effective and versatile fruition of most diverse scaffold designs. The modular system is highly flexible and can even be used for complicated layouts and varying height structures to be scaffolded.

ALFIX modular systems are available in two versions: ALFIX Modul Plus II of 1.57-2.07-2.57-3.07 m and ALFIX Modul metric of 1.50-2.00-2.50-3.00 m.

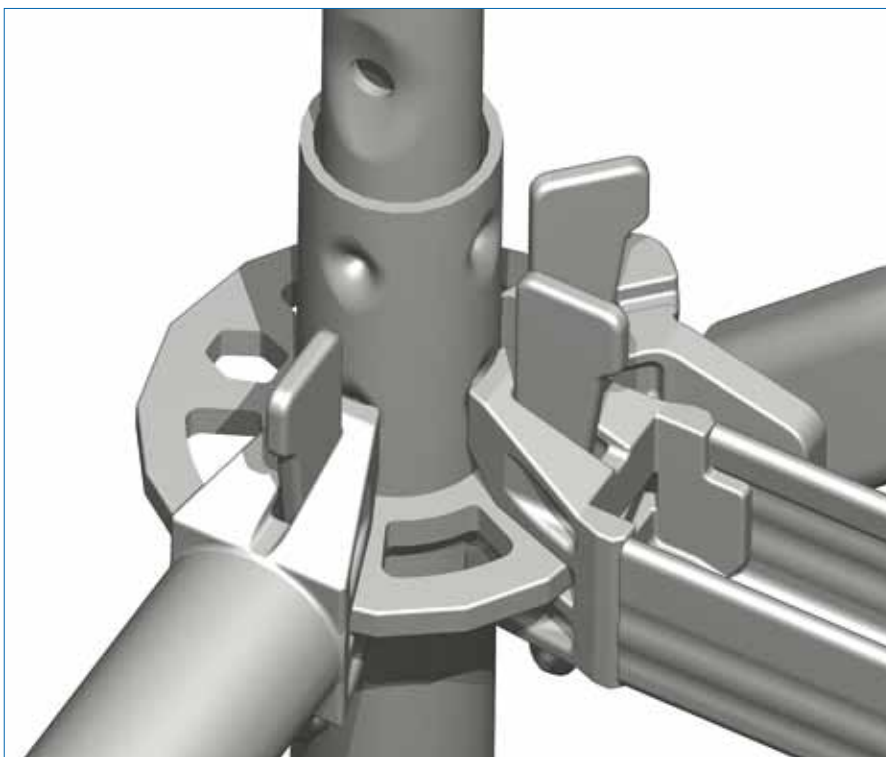

Perforated steel disc with 4 small openings for rectangular positioning of ledgers and 4 wide openings for aligning ledgers or diagonal braces at angles above or below 90°. Detailed information regarding the connectors' load-bearing capability can be found on page 32.



Assembly options for applications as load class 3 façade scaffolding with 0.73 m bay width, or load class 4 scaffolding with 1.09 m bay width, can be taken from the technical approval Z-8.22-906 and the corresponding instructions for erection and use.

**Assembly upright, steel**

- with pressed-in or screwed-in spigot fitting (SF)
- steel tubing 48.3 x 3.2 mm, zinc-plated
- perforated disks every 50 cm
- distance of tubing, lower edge to first perforated disc: 400 mm
- see also permissible upright loads on page 33

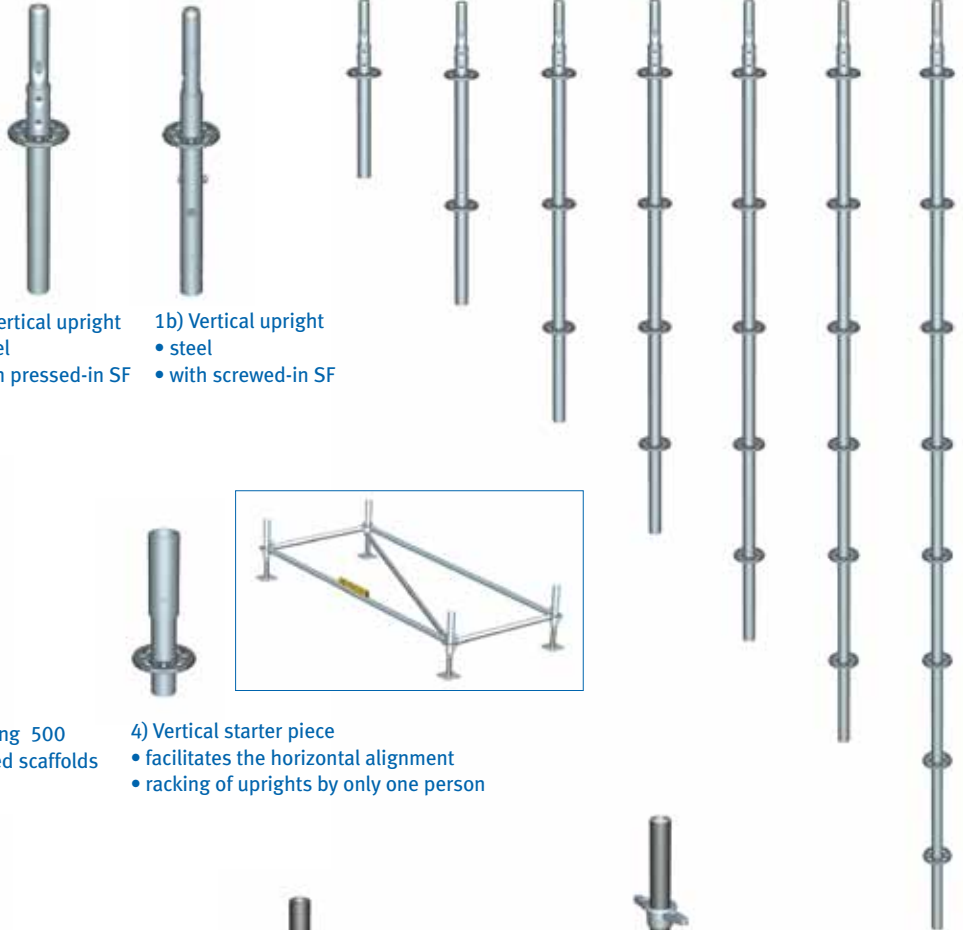

1a) Vertical upright  
• steel  
• with pressed-in SF

1b) Vertical upright  
• steel  
• with screwed-in SF

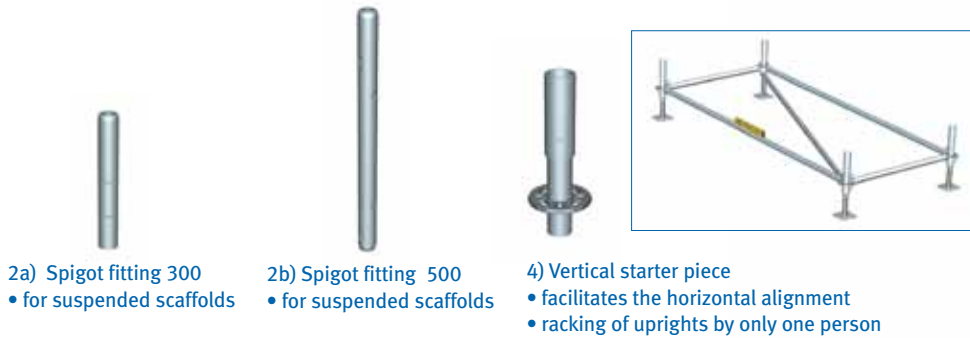

2a) Spigot fitting 300  
• for suspended scaffolds

2b) Spigot fitting 500  
• for suspended scaffolds

4) Vertical starter piece  
• facilitates the horizontal alignment  
• racking of uprights by only one person

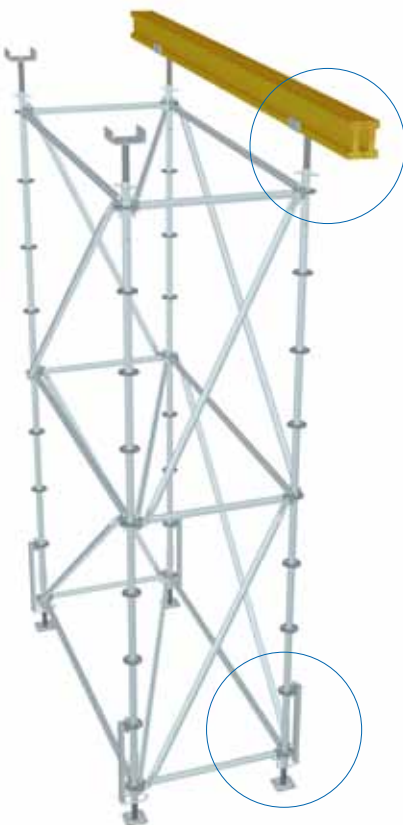

5) Base jack  
• max. spindle travel:  
0.25 m (L=0.40 m)  
0.45 m (L=0.60 m)  
0.60 m (L=0.80 m)

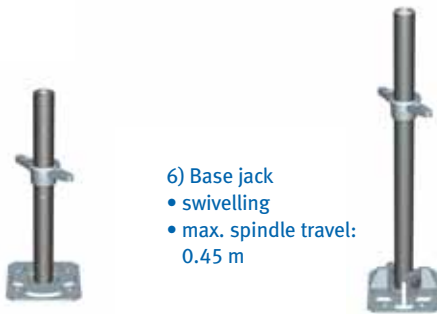

6) Base jack  
• swivelling  
• max. spindle travel:  
0.45 m



7) Head spindle "U"  
• opening width 160 mm  
• supporting length 150 mm  
• boreholes for fixing formwork girders  
• max. spindle travel 0.45 m



8) Base jack locking device  
• ensures the safe seating of base jack during crane operations



9) Scaffolding castor

Fig.	Designation	Dimensions L/HxW [m]	Weight [kg]	Article number	Price [€]
1a	<b>Vertical upright</b> with pressed-in spigot fitting, steel tubing 48.3 x 3.2 mm; hot-dip galvanised; perforated discs every 50 cm, distance of tubing, lower edge to first perforated disc: 400 mm	0.50	3.2	40 04 050	<b>15.25</b>
		1.00	5.5	40 04 100	<b>19.35</b>
		1.50	7.7	40 04 150	<b>27.65</b>
		2.00	10.1	40 04 200	<b>31.80</b>
		2.50	12.3	40 04 250	<b>43.30</b>
		3.00	14.6	40 04 300	<b>47.00</b>
		4.00	19.2	40 04 400	<b>60.30</b>
1b	<b>Vertical upright</b> with screwed-in spigot fitting, for suspended scaffolds, including special bolts, steel tubing 48.3 x 3.2 mm; hot-dip galvanised; perforated discs every 50 cm, distance of tubing, lower edge to first perforated disc: 400 mm	0.50	4.0	40 05 050	<b>23.20</b>
		1.00	6.2	40 05 100	<b>27.30</b>
		1.50	8.5	40 05 150	<b>36.75</b>
		2.00	10.8	40 05 200	<b>39.70</b>
		2.50	13.0	40 05 250	<b>51.25</b>
		3.00	15.3	40 05 300	<b>54.90</b>
4.00	19.9	40 05 400	<b>70.75</b>		
2a	<b>Spigot fitting 300</b> steel tubing; hot-dip galvanised; as spare part for vertical upright with screwed-in spigot up to year of manufacture 2007	0.27	1.0	83 40 002	<b>7.50</b>
2b	<b>Spigot fitting 500</b> steel tubing; hot-dip galvanised; as spare part for vertical upright with screwed-in spigot from the year of manufacture 2008	0.52	1.7	83 40 050	<b>7.95</b>
3	<b>Special bolt</b> (12 x 60 mm) with M12 hexnut, self-locking		0.05	40 99 000	<b>0.65</b>
4	<b>Vertical starter piece</b> steel; hot-dip galvanised	0.41	1.8	40 00 041	<b>9.10</b>
5	<b>Base jack</b> with smooth running tubular spindle and grip nut, safety catch against removing baseplate 15 x 15 cm	0.40	2.9	11 51 040	<b>11.75</b>
		0.60	3.6	11 51 060	<b>12.85</b>
		0.80	4.9	11 51 080	<b>18.85</b>
6	<b>Base jack</b> swivelling	0.60	4.5	11 52 060	<b>28.55</b>
7	<b>Head spindle "U"</b>	0.60	6.0	41 59 000	<b>28.55</b>
8	<b>Locking device for base jack</b>	0.65	3.5	41 52 003	<b>16.60</b>
9	<b>ALFIX scaffolding castor</b> diameter 200 mm, max. spindle travel 0.35 m  max. safe load: 6 kN  max. safe load: 10 kN				
		0.70	6.7	14 12 001	<b>69.55</b>
		0.70	10.0	14 12 004	<b>82.80</b>

### Deck ledgers

- available as cylindrical profile (for decks with circular tube support) -**tube ledger**- and U-profile for locating standard decking - **U-ledger**
- load capacities, see tables on page 31

### Tube ledgers

- available in different lengths
- reinforced ledgers for use at higher loads
- usable as horizontal connecting element, side protection and - in reinforced design - as deck ledger
- coloured indication of bay length (see p. 12)

### U-ledgers

- various lengths, available in reinforced design or as bridging ledgers, depending on length
- locating element for standard deckings safeguarded against lifting through deck retainers
- if deck retainers are used in façade scaffoldings (see standard design, technical approval/instructions for erection and use) it can be abstained from using tube ledgers on deck level

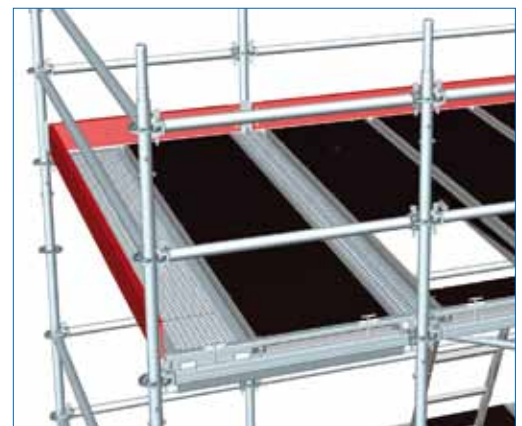
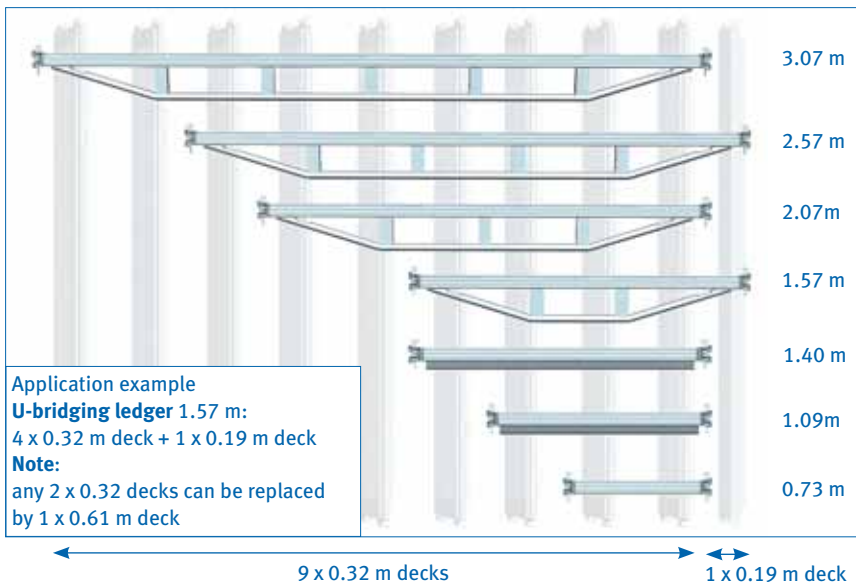
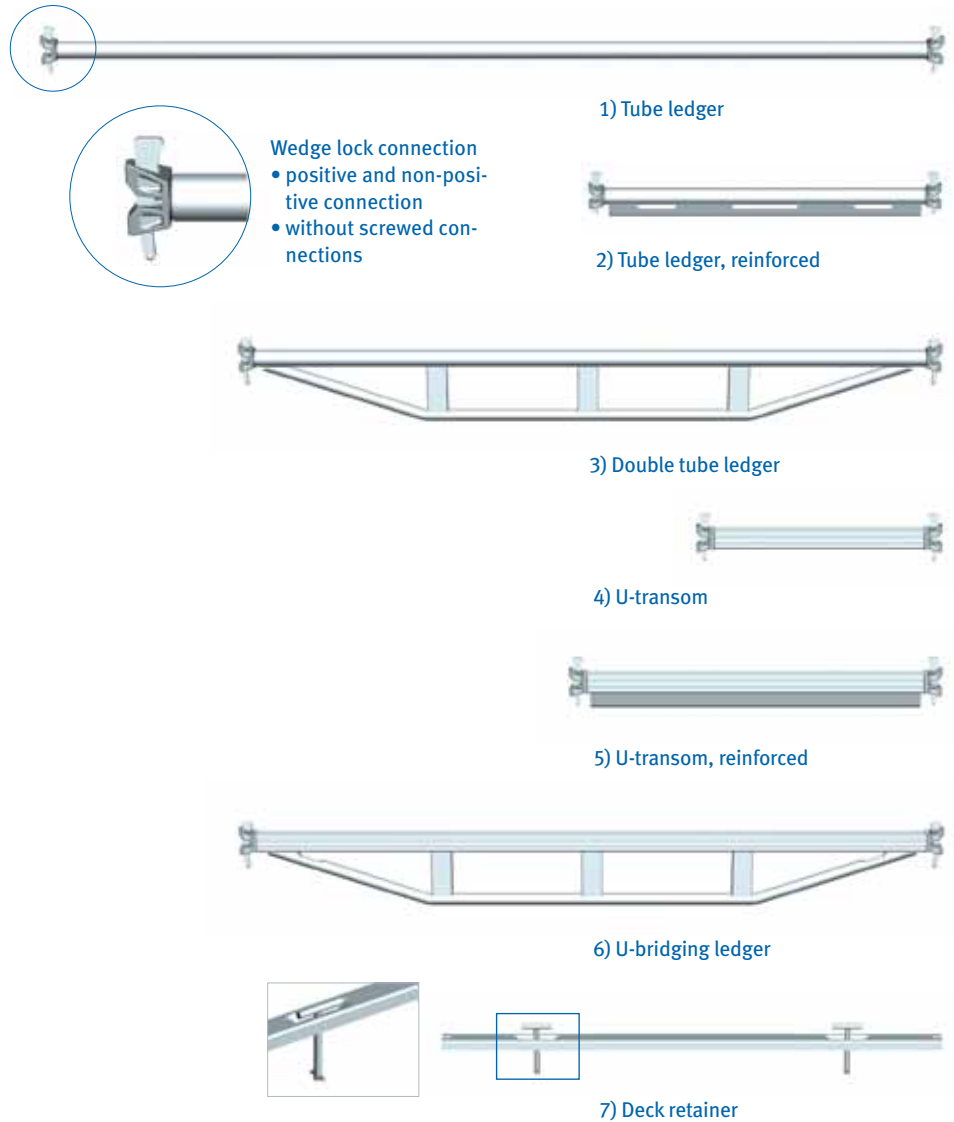

Application example: Deck retainer

Fig.	Designation	Dimensions L/HxW [m]	Weight [kg]	Article number	Price [€]
1	<b>Tube ledger</b> steel tubing 48.3 mm x 3.2 mm hot-dip galvanised	0.36	1.8	40 60 036	<b>18.40</b>
		0.39	2.0	40 60 039	<b>18.40</b>
		0.45	2.3	40 60 045	<b>18.40</b>
		0.73	3.2	40 60 073	<b>14.85</b>
		1.04	4.2	40 60 104	<b>17.75</b>
		1.09	4.5	40 60 109	<b>17.75</b>
		1.29	5.0	40 60 129	<b>21.70</b>
		1.40	5.6	40 60 140	<b>21.70</b>
		1.57	6.3	40 60 157	<b>21.70</b>
		2.07	8.1	40 60 207	<b>25.40</b>
		2.57	9.9	40 60 257	<b>29.00</b>
		3.07	11.8	40 60 307	<b>32.70</b>
4.14	16.5	40 60 414	<b>47.45</b>		
2	<b>Tube ledger, reinforced</b> steel tubing 48.3 mm x 3.2 mm hot-dip galvanised	1.09	5.9	40 61 109	<b>28.55</b>
		1.29	7.1	40 61 129	<b>32.25</b>
		1.40	8.0	40 61 140	<b>34.80</b>
3	<b>Double tube ledger</b> steel tubing 48.3 mm x 3.2 mm hot-dip galvanised	1.57	9.8	40 61 157	<b>45.90</b>
		2.07	12.7	40 61 207	<b>55.30</b>
		2.57	16.4	40 61 257	<b>65.10</b>
		3.07	19.5	40 61 307	<b>75.00</b>
4	<b>U-transom</b> steel hot-dip galvanised	0.45	2.0	40 65 045	<b>16.30</b>
		0.73	3.0	40 65 073	<b>17.30</b>
5	<b>U-transom, reinforced</b> steel hot-dip galvanised	1.04	6.0	40 65 104	<b>27.65</b>
		1.09	6.2	40 65 109	<b>27.65</b>
		1.29	7.3	40 65 129	<b>32.25</b>
		1.40	7.9	40 65 140	<b>35.55</b>
6	<b>U-bridging ledger</b> steel hot-dip galvanised	1.57	9.2	40 65 157	<b>45.90</b>
		2.07	12.4	40 65 207	<b>55.30</b>
		2.57	15.1	40 65 257	<b>65.10</b>
		3.07	18.1	40 65 307	<b>75.00</b>
7	<b>Deck retainer</b>	0.45	0.8	40 98 045	<b>9.10</b>
		0.73	1.4	40 98 073	<b>13.45</b>
		1.09	1.9	40 98 109	<b>14.80</b>
		1.40	2.5	40 98 140	<b>22.00</b>
		1.57	2.9	40 98 157	<b>27.90</b>
		2.07	3.9	40 98 207	<b>34.60</b>
		2.57	4.8	40 98 257	<b>39.15</b>
		3.07	5.4	40 98 307	<b>43.75</b>

### Intermediate deck ledger

- edge design: one side - bearing on tube ledger, one side - fastening on steel planking
- centre design: fastening on steel plankings on both sides
- available as tubular profile (for plankings with circular tube support) or U-profile



1a) Intermediate deck ledger RE, edge design



1b) Intermediate deck ledger RE, centre design



2a) Intermediate deck ledger U, edge design



2b) Intermediate deck ledger U, centre design

### Decking and planking ledger

- for laying on tube ledgers on both sides
- application for preferably system-free decks or for creating openings within the scaffold decking when planks with tube fixtures are used, also suitable as side protection
- permissible distributed load must be observed
- available as tubular profile (for plankings with circular tubing fixture =RE) or U-profile



Application example:  
**Decking and planking ledger** used  
with system-free decks



3) Decking and planking ledger RE



4) Decking and planking ledger U



5) Recess bracket holder



6) Recess bracket starting piece

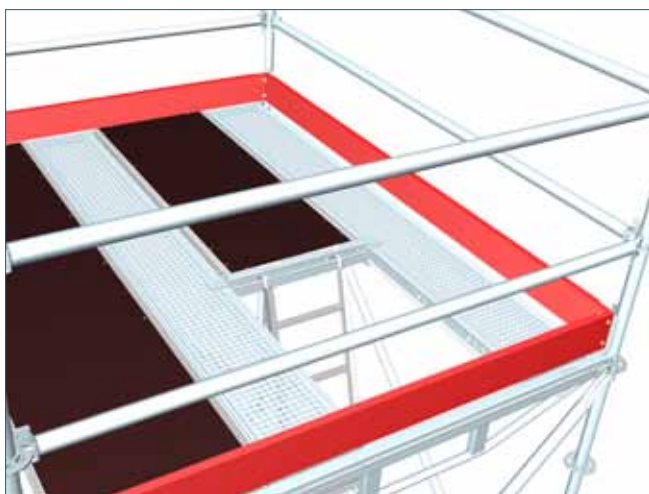

Application example:  
**Intermediate deck ledger U** in centre design (Fig. 2b) to be applied in steel deckings



Application example:  
**Decking and planking ledger** facilitates the creation of hatch-type access through the use of shorter decks within a longer bay.

Fig.	Designation	Dimensions L/HxW [m]	Weight [kg]	Article number	Price [€]
1a	<b>Intermediate deck ledger</b> RE steel; hot-dip galvanised Edge design	0.64	3.9	40 53 064	<b>23.95</b>
		0.96	5.1	40 53 096	<b>27.20</b>
1b	Centre design	0.64	4.2	40 51 064	<b>23.95</b>
		0.96	5.4	40 51 096	<b>27.20</b>
2a	<b>Intermediate deck ledger</b> U steel; hot-dip galvanised Edge design	0.64	3.6	40 54 064	<b>23.85</b>
		0.96	6.9	40 54 096	<b>45.10</b>
2b	Centre design	0.64	4.1	40 52 065	<b>30.45</b>
		0.96	5.3	40 52 097	<b>45.10</b>
3	<b>Decking and planking ledger</b> RE steel; hot-dip galvanised	0.73	3.4	40 50 073	<b>16.60</b>
		1.09	4.7	40 50 109	<b>18.90</b>
		1.57	7.8	40 50 157	<b>26.75</b>
		2.07	9.9	40 50 207	<b>33.15</b>
		2.57	12.1	40 50 257	<b>39.60</b>
		3.07	14.6	40 50 307	<b>45.55</b>
4	<b>Decking and planking ledger</b> U steel; hot-dip galvanised	0.73	3.0	40 55 073	<b>16.60</b>
		1.09	4.1	40 55 109	<b>18.90</b>
5	<b>Recess bracket holder</b> with integrated halfcoupler; for all scaffolding systems up to widths of 0.65 m and 1.00 m	0.60	2.9	14 51 060	<b>29.00</b>
6	<b>Recess bracket starting piece</b>	0.35	1.7	14 40 000	<b>4.95</b>

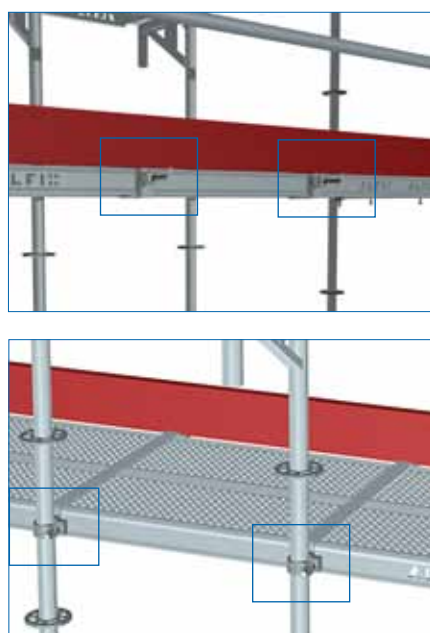
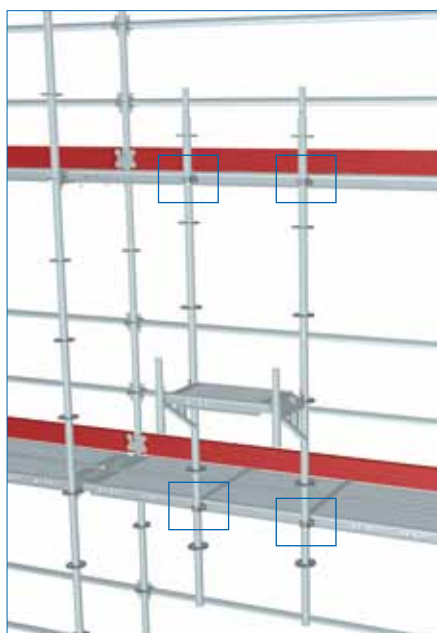

### Recess bracket holder

Per storey, two recess bracket holders are placed onto the decks and fixed by tensioning screws. The holders fit on every scaffolding deck. Their arrangement must ensure that the recess can be secured by a grid-like decking and that the side-wise recess gap does not exceed 30 cm according to the scaffolding regulations. Uprights are vertically fixed to the halfcouplers, which are integrated into the holder, across two or more (depending on recess brackets) storeys. The uprights serve for fixing the brackets at the appropriate height.

Application example:  
Fixing of **recess bracket holder** by means of two tensioning screws per storey

### Toeboard

- applicable when system decks (U-ledger) and decks with tube fixture (tube ledger) are used
- fixture of toeboards between vertical upright and wedge
- made of wood or aluminium for special requirements, e.g. for industrial scaffoldings (fire retardancy)



### Safety double guardrail

- usable as advanced side protection for façade scaffold module

### Modular double-end guardrail

- usable as end side protection for façade scaffolding module

### Safety mesh guard

- built-in guard net system
- mesh size 60 mm
- green
- incl. tube ledger at the top and aluminium tube (40mm) at the bottom, with spigot fitting for bay-by-bay extension
- fastening on the left and right with integrated fixing cords
- alternative system-independent nets, see ALFIX Accessories Catalogue

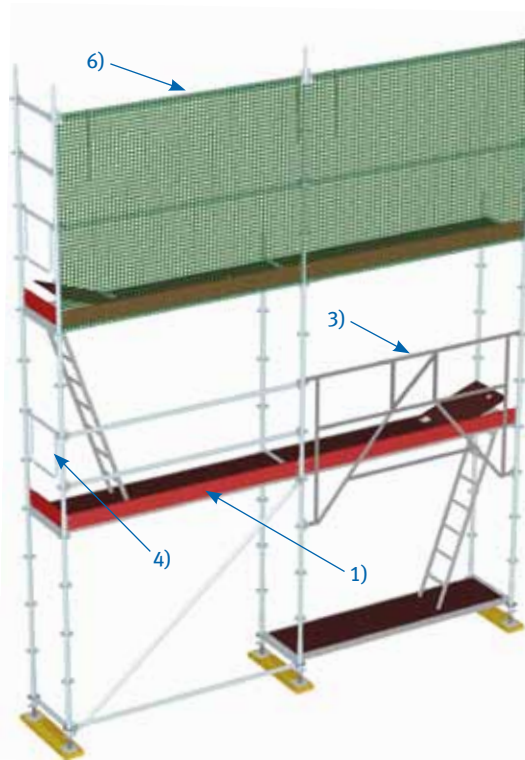
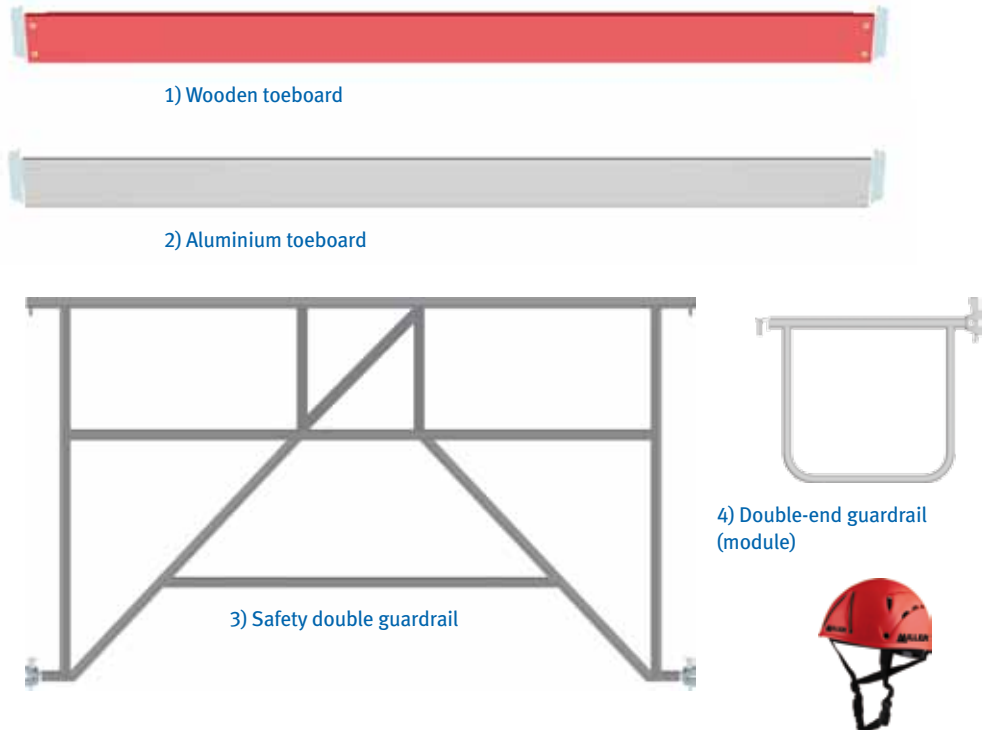

Application example **Façade scaffolding module**



6) PPE scaffolding kit 1 - Fig.: AX11 belt, backpack, BFD lanyard



6) PPE scaffolding kit 2 - Fig.: Revolution R2 Scaff belt, equipment bag, Manyard Edge lanyard and tool bag for scaffolding ratchet

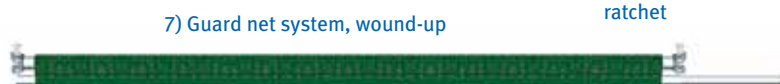

7) Guard net system, wound-up

Fig.	Designation	Dimensions L/HxW [m]	Weight [kg]	Article number	Price [€]
1	<b>Wooden toeboard</b> framed with fittings; height 15 cm	0.73	1.6	40 95 073	<b>11.20</b>
		1.09	2.3	40 95 109	<b>11.65</b>
		1.29	2.7	40 95 129	<b>17.60</b>
		1.40	3.0	40 95 140	<b>12.00</b>
		1.57	3.3	40 95 157	<b>12.45</b>
		2.07	4.2	40 95 207	<b>13.35</b>
		2.57	5.3	40 95 257	<b>14.35</b>
		3.07	6.3	40 95 307	<b>15.25</b>
2	<b>Aluminium toeboard</b> height 15 cm	0.73	1.2	40 95 076	<b>16.40</b>
		1.09	1.7	40 95 112	<b>19.65</b>
		1.29	1.9	40 95 131	<b>20.80</b>
		1.40	2.1	40 95 143	<b>21.55</b>
		1.57	2.3	40 95 160	<b>22.95</b>
		2.07	3.0	40 95 210	<b>28.55</b>
		2.57	3.6	40 95 260	<b>34.20</b>
		3.07	4.3	40 95 310	<b>39.80</b>
3	<b>Safety double guardrail, aluminium</b>	1.29	6.9	40 39 129	<b>105.05</b>
		1.57	7.4	40 39 157	<b>109.50</b>
		2.07	8.4	40 39 207	<b>119.00</b>
		2.57	10.0	40 39 257	<b>124.70</b>
		3.07	11.3	40 39 307	<b>130.40</b>
4	<b>Double-end guardrail (module)</b> steel-tubing 33.7 mm; hot-dip galvanised	0.73	3.5	40 62 073	<b>23.95</b>
		1.09	4.2	40 62 109	<b>27.20</b>
5	<b>Safety helmet with chin straps; white or red</b>			37 50 018	<b>61.10</b>
6	<b>Personal protective equipment against falling (PPE)</b> EN 354 / 355 / 361 / 363; sharp-edge resistant				
		<b>PPE: scaffolding kit 1</b> (AX 11 belt; 2.5 m; with dorsal eyebolt; incl. dorsal eyebolt extension and backpack)		37 67 007	<b>132.50</b> <small>Special net price</small>
		<b>PPE scaffolding kit 2</b> (Revolution R2 Scaff belt; 2.50m; Manyard Edge lanyard; incl. equipment bag)		37 67 009	<b>250.60</b> <small>Special net price</small>
		<b>Tool bag for scaffolding ratchets</b>		37 50 017	<b>15.70</b>
7	<b>Guard net system</b> height 2.00 m green mesh size 60 mm incl. tube ledger and aluminium tube with spigot fitting incl. two fixing cords on the left and right	2.07	4.7	14 22 207	<b>105.55</b>
		2.57	6.8	14 22 257	<b>119.95</b>
		3.07	8.1	14 22 307	<b>138.45</b>

### Vertical diagonal braces

- steel tubing 48.3 mm x 2.7 mm
- zinc-plated
- wedge lock principle for positive and non-positive connections
- without screwed connections
- for bracing the basic scaffold
- special sizes possible
- static values, see load capacity tables on page 33

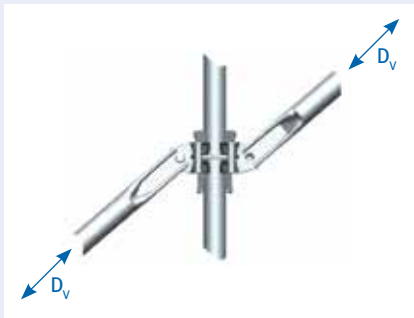

- different bay lengths

coloured indication of bay length:

0.73 m	1.09 m	1.29 m	1.40 m
1.57 m	2.07 m	2.57 m	3.07 m

Marking of installation height through up to 4 strips:

2.00 m	██████████
1.50 m	██████████
1.00 m	██████████
0.50 m	██████████

(Example: 3.07 m x 2.00 m)



- 1 to 4) Vertical diagonal brace
- thirty-two different diagonal sizes available
  - other dimensions on request



Labels on tube ledgers for quick indication of bay length and on diagonal braces for specifying bay length and installation height

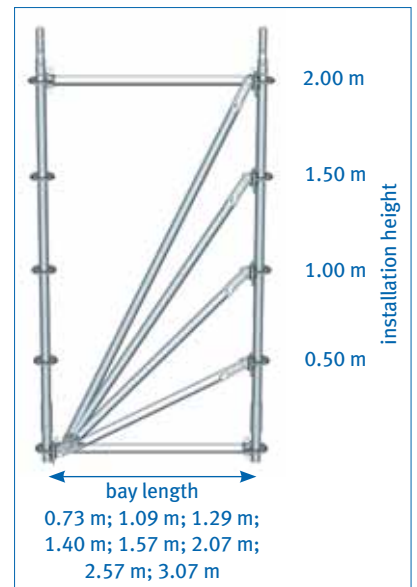

### Horizontal diagonal braces

- steel tubing 42.4 mm x 2 mm
- zinc-plated
- available for any possible combination of [bay length] x [bay width]
- screwless pin fixing
- bracing of horizontal planes for scaffolds without planking

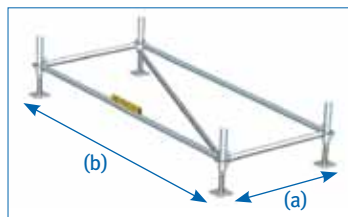

Horizontal diagonal brace

- for aligning the modular scaffold structure at right angles and for horizontal bracing of surface-oriented space frameworks
- (a) = 0.73 m to 3.07 m
- (b) = 0.73 m to 3.07 m

### Horizontal ledger

- steel tubing 48.3 mm x 3.2 mm
- zinc-plated
- available in different lengths
- wedge lock principle for positive and non-positive connections
- without screwed connections
- bracing of horizontal planes within a space framework

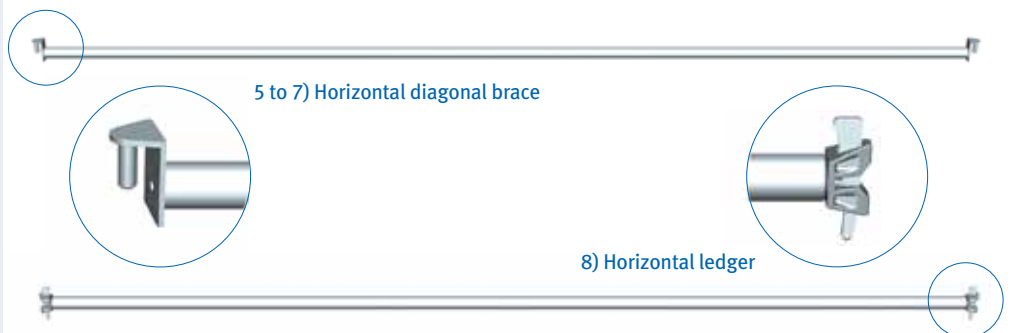

Fig.	Designation	Dimensions L/HxW [m]	Weight [kg]	Article number	Price [€]
1	<b>Vertical diagonal brace</b> for bay height 2.00 m	0.73	7.5	40 21 200	<b>29.90</b>
		1.09	7.8	40 22 200	<b>30.45</b>
		1.40	8.3	40 23 200	<b>30.90</b>
		1.57	8.8	40 24 200	<b>31.35</b>
		2.07	9.7	40 25 200	<b>32.70</b>
		2.57	10.9	40 26 200	<b>35.05</b>
		3.07	12.2	40 27 200	<b>37.30</b>
2	<b>Vertical diagonal brace</b> for bay height 1.50 m	1.57	7.7	40 24 150	<b>33.15</b>
		2.07	8.8	40 25 150	<b>34.65</b>
		2.57	10.0	40 26 150	<b>36.75</b>
		3.07	11.0	40 27 150	<b>39.35</b>
3	<b>Vertical diagonal brace</b> for bay height 1.00 m	1.57	6.5	40 24 100	<b>32.15</b>
		2.07	7.8	40 25 100	<b>33.60</b>
		2.57	9.0	40 26 100	<b>35.75</b>
		3.07	10.3	40 27 100	<b>38.35</b>
4	<b>Vertical diagonal brace</b> for bay height 0.50 m	1.57	6.0	40 24 050	<b>31.15</b>
		2.07	7.4	40 25 050	<b>32.60</b>
		2.57	8.8	40 26 050	<b>34.75</b>
		3.07	10.0	40 27 050	<b>37.30</b>
5	<b>Horizontal diagonal brace</b> for bay length L 2.07 m	0.73	4.8	40 45 073	<b>27.75</b>
		1.09	5.0	40 45 109	<b>29.05</b>
6	<b>Horizontal diagonal brace</b> for bay length L 2.57 m	0.73	6.0	40 46 073	<b>31.35</b>
		1.09	6.3	40 46 109	<b>32.15</b>
7	<b>Horizontal diagonal brace</b> for bay length L 3.07 m	0.73	6.6	40 47 073	<b>35.85</b>
		1.09	7.8	40 47 109	<b>36.05</b>
8	<b>Horizontal ledger</b>	1.57 x 1.57	8.5	40 44 158	<b>34.10</b>
		2.07 x 2.07	10.8	40 45 208	<b>42.40</b>
		2.57 x 2.57	13.3	40 46 258	<b>50.65</b>
		3.07 x 3.07	15.5	40 47 308	<b>58.95</b>

### Steel deck

- high loadability
- non-slip surface
- zinc-plated
- in RE design, incl. deck retainer (RE=tube fixture: components for fixing circular tubing planks)



1) Steel deck



2) Steel deck RE Modul Plus II

### Solid wooden deck

- impregnated
- triple bonded
- thickness: 48 mm
- ends with steel head piece



3) Solid wooden deck

### Aluminium frame platform

- highly lightweight
- water-resistant screen-printed decking
- standard width: 60 cm
- fixing and decking replaceable



4) Aluminium frame platform

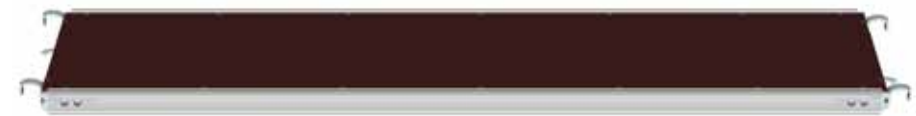

5) Aluminium frame platform RE

### Solid aluminium deck

- completely made of aluminium
- profile height: 48 mm
- consisting of hollow chamber profiles with non-skid longitudinal grooves
- stacking bead, enabling safe storing
- stacking bead downwards, prevents water and ice deposition



6) Solid aluminium deck 0.32 m



7) Solid aluminium deck 0.60 m

Fig.	Designation	Load class	Dimensions L/HxW [m]	Weight [kg]	Article number	Price [€]
1	<b>Steel deck; 0.32 m</b> hot-dip galvanised; perforated, non-slip	6	0.73 x 0.32	5.6	12 21 073	<b>38.55</b>
		6	1.09 x 0.32	8.1	12 21 109	<b>39.35</b>
		6	1.57 x 0.32	11.4	12 21 157	<b>40.50</b>
		6	2.07 x 0.32	13.7	12 21 207	<b>45.40</b>
		5	2.57 x 0.32	17.1	12 21 257	<b>52.30</b>
		4	3.07 x 0.32	20.5	12 21 307	<b>59.40</b>
2	<b>Steel deck RE Modul Plus II; 0.32 m</b> hot-dip galvanised; with circular tubing support	6	0.73 x 0.32	6.1	40 20 073	<b>45.55</b>
		6	1.09 x 0.32	8.6	40 20 109	<b>45.75</b>
		6	1.57 x 0.32	11.9	40 20 157	<b>47.00</b>
		6	2.07 x 0.32	14.2	40 20 207	<b>51.85</b>
		5	2.57 x 0.32	17.6	40 20 257	<b>58.95</b>
		4	3.07 x 0.32	20.9	40 20 307	<b>66.80</b>
3	<b>Solid wooden deck; 0.32 m</b> bonded; secured by a system-compatible steel head piece at both ends	6	0.73 x 0.32	6.5	12 31 073	<b>23.50</b>
		6	1.09 x 0.32	9.0	12 31 109	<b>24.55</b>
		6	1.57 x 0.32	12.5	12 31 157	<b>33.55</b>
		5	2.07 x 0.32	16.0	12 31 207	<b>39.60</b>
		4	2.57 x 0.32	19.0	12 31 257	<b>44.25</b>
		3	3.07 x 0.32	23.0	12 31 307	<b>50.80</b>
4	<b>Aluminium frame platform; 0.60 m</b> with water-resistant screen-printed plywood surface	3	1.57 x 0.60	11.5	12 01 157	<b>81.30</b>
		3	2.07 x 0.60	14.5	12 01 207	<b>91.15</b>
		3	2.57 x 0.60	17.6	12 01 257	<b>101.05</b>
		3	3.07 x 0.60	20.7	12 01 307	<b>120.75</b>
		3	4.14 x 0.32	19.1	12 01 414	<b>135.60</b>
5	<b>Aluminium frame platform RE; 0.60 m</b> with water-resistant screen-printed plywood surface	3	1.57 x 0.60	13.3	41 60 157	<b>107.20</b>
		3	2.07 x 0.60	16.3	41 60 207	<b>117.45</b>
		3	2.57 x 0.60	19.4	41 60 257	<b>130.60</b>
		3	3.07 x 0.60	22.5	41 60 307	<b>150.25</b>
		3	4.14 x 0.32	20.7	41 61 414	<b>156.50</b>
6	<b>Solid aluminium decking; 0.32 m</b>	6	1.09 x 0.32	4.7	12 11 109	<b>66.90</b>
		6	1.57 x 0.32	6.5	12 11 157	<b>75.35</b>
		6	2.07 x 0.32	8.4	12 11 207	<b>88.95</b>
		5	2.57 x 0.32	10.3	12 11 257	<b>102.55</b>
		4	3.07 x 0.32	12.2	12 11 307	<b>117.45</b>
		3	4.14 x 0.32	16.3	12 11 414	<b>152.25</b>
7	<b>Solid aluminium decking; 0.60 m</b>	6	1.09 x 0.60	9.1	12 12 109	<b>102.70</b>
		6	1.57 x 0.60	12.8	12 12 157	<b>110.00</b>
		6	2.07 x 0.60	16.6	12 12 207	<b>135.30</b>
		5	2.57 x 0.60	19.8	12 12 257	<b>161.50</b>
		4	3.07 x 0.60	23.2	12 12 307	<b>186.75</b>

\* A load class overview is available under the topic "Technical Details" on page 34.

### Aluminium frame platforms with hatch-type access

- exchangeable fixtures and deckings
- optionally with or without integrated storey ladder
- convenient and fail-safe ladder and hatch latching
- unlatching of ladder is possible from above
- water-resistant screen-printed planking
- version without ladder, with hatch notches for fixing separate storey ladders (see p. 28 - 29), particularly suitable for ladder accesses less than or equal to 2.07 m
- **Alternatively** to hatch-type accesses, stairways can be used as an adjoining separate structure (stairway tower). (see p. 28-29)

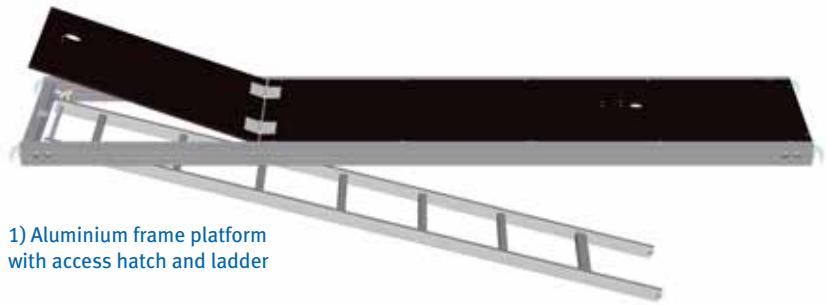

1) Aluminium frame platform with access hatch and ladder



2) Aluminium frame platform RE shifted hatch-type access with step tread and ladder



3) Aluminium frame platform with access hatch, without ladder



4) Aluminium frame platform RE shifted hatch-type access with step tread and ladder

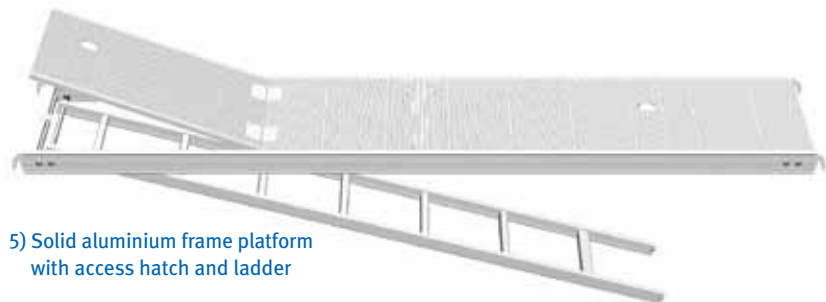

5) Solid aluminium frame platform with access hatch and ladder



6) Solid aluminium frame platform RE shifted hatch-type access with step tread and ladder

### Alternative

Alternatively to hatch-type accesses, stairways can be used as an adjoining separate structure (stairway tower). (see p. 28-29)

### Solid aluminium frame platform with access hatch and ladder

- integrated storey ladder
- unlatching of ladder is possible from above
- eminently durable and weather-proof
- completely made of aluminium for special requirements, e.g. for industrial scaffoldings (fire retardancy)

Fig.	Designation	Load class	Dimensions L/HxW [m]	Weight [kg]	Article number	Price [€]
1	<b>Aluminium frame platform; 0.60 m</b> with access hatch and integrated aluminium storey ladder; with water-resistant screen-printed plywood surface	3	2.57 x 0.60	20.9	12 04 257	<b>212.50</b>
		3	3.07 x 0.60	24.0	12 04 307	<b>242.50</b>
2	<b>Aluminium frame platform RE; 0.60 m</b> with access hatch and integrated aluminium storey ladder; with water-resistant screen-printed plywood surface	3	2.57 x 0.60	23.4	41 63 257	<b>227.45</b>
		3	3.07 x 0.60	26.5	41 63 307	<b>257.40</b>
3	<b>Aluminium frame platform</b> with access hatch, <b>without ladder</b> ; with water-resistant screen-printed plywood surface	3	2.07 x 0.60	15.3	12 05 207	<b>138.90</b>
		3	2.57 x 0.60	18.4	12 05 257	<b>152.45</b>
		3	3.07 x 0.60	21.5	12 05 307	<b>176.45</b>
4	<b>Aluminium frame platform RE; 0.60 m</b> with access hatch, <b>without ladder</b> ; with water-resistant screen-printed plywood surface	3	2.07 x 0.60	18.2	41 63 208	<b>179.30</b>
		3	2.57 x 0.60	21.4	41 63 258	<b>198.70</b>
		3	3.07 x 0.60	24.5	41 63 308	<b>222.25</b>
5	<b>Solid aluminium frame platform; 0.60 m</b> with access hatch and integrated aluminium storey ladder	3	2.57 x 0.60	21.8	12 07 257	<b>250.85</b>
			3.07 x 0.60	25.0	12 07 307	<b>279.90</b>
6	<b>Solid aluminium frame platform RE; 0.60 m</b> with access hatch and integrated aluminium storey ladder	3	2.57 x 0.60	23.6	41 67 257	<b>262.30</b>
			3.07 x 0.60	26.8	41 67 307	<b>291.50</b>

\* A load class overview is available under the topic "Technical Details" on page 34.

Load class	Uniformly distributed load q [kN/m <sup>2</sup> ]	Load class	Uniformly distributed load q [kN/m <sup>2</sup> ]
1	0.75	4	3.00
2	1.50	5	4.50
3	2.00	6	6.00



Hatch latching



Ladder latching



**Application example: Access hatch**

Normally, the installation of access hatches is carried out alternating one above the other. The bottom-most footfall level is to be created by system decks and serves as a set-up area for the first storey ladder.

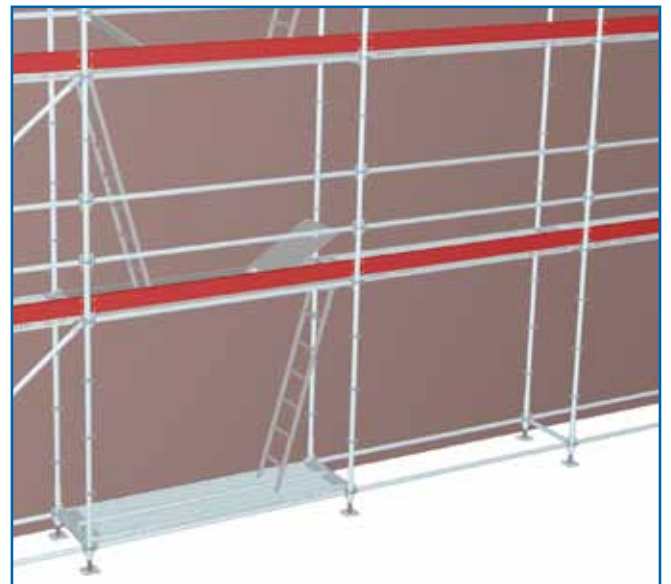

**Intermediate deck**

- serves as equalising decking for deck surfaces of varying widths
- predominantly required for surface-oriented space framework

**Gap cover**

- for covering constructively induced gaps on the bracket level
- to be slipped onto the tube ledger
- When using decks with tube fixtures (RE) a separate gap cover is required. Available upon request.

**Steel plank**

- for covering or closing corner areas or other structurally induced openings
- positioning solely on steel decks
- An overlapping length of 250 mm is required!

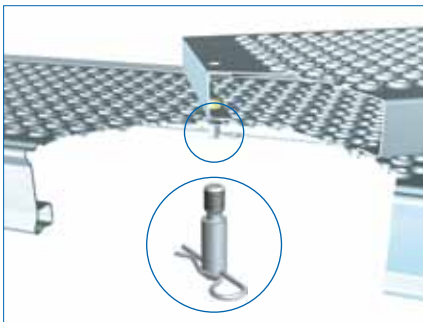

Application example: **Steel plank** with locking and spring cotter pins

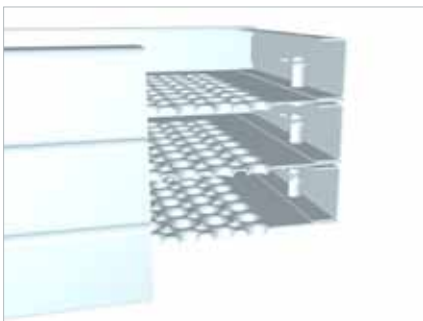

Application example: **Steel plank** very good stackability of individual steel planks on top of each other



1) Intermediate deck



2) Intermediate deck RE



3) Gap cover



4) Steel plank with securing contrivance



5) Spring cotter pin



6) Corner deck  
• rigid for angles of 45°- 60°  
• with integrated aluminium toeboard



Application example: **Corner deck**

Fig.	Designation	Load class	Dimensions L/HxW [m]	Weight [kg]	Article number	Price [€]
1	<b>Intermediate deck</b> steel hot-dip galvanised	6	1.57 x 0.19	8.6	12 25 157	<b>34.60</b>
		6	2.07 x 0.19	11.2	12 25 207	<b>39.55</b>
		5	2.57 x 0.19	13.9	12 25 257	<b>46.20</b>
		4	3.07 x 0.19	16.5	12 25 307	<b>53.65</b>
2	<b>Intermediate deck RE</b> steel hot-dip galvanised	6	1.57 x 0.19	9.2	40 30 157	<b>40.95</b>
		6	2.07 x 0.19	11.8	40 30 207	<b>45.90</b>
		5	2.57 x 0.19	14.5	40 30 257	<b>52.75</b>
		4	3.07 x 0.19	17.1	40 30 307	<b>60.30</b>
3	<b>Gap cover</b> made of aluminium chequer plates; for system decks  When using decks with tube fixtures (RE) a separate gap cover is required. Available upon request.		1.09 x 0.19	2.0	40 31 109	<b>24.05</b>
			1.57 x 0.19	3.0	40 31 157	<b>28.75</b>
			2.07 x 0.19	4.0	40 31 207	<b>33.70</b>
			2.57 x 0.19	5.1	40 31 257	<b>38.85</b>
			3.07 x 0.19	6.1	40 31 307	<b>43.80</b>
4	<b>Steel plank</b> with locking and spring cotter pin	6	1.00 x 0.3	5.5	12 24 100	<b>35.45</b>
		6	1.50 x 0.3	8.0	12 24 150	<b>44.10</b>
		5	2.00 x 0.3	10.5	12 24 200	<b>52.60</b>
		3	2.50 x 0.3	12.8	12 24 250	<b>59.35</b>
5	<b>Spring cotter pin</b> spare part for item 4			0.03	73 04 006	<b>0.45</b>
6	<b>Corner deck</b> made of aluminium, with integrated toeboard rigid for angles of 45°- 60°	3	0.73 x 0.6	7.0	40 91 000	<b>151.25</b>

\* A load class overview is available under the topic "Technical Details" on page 34.

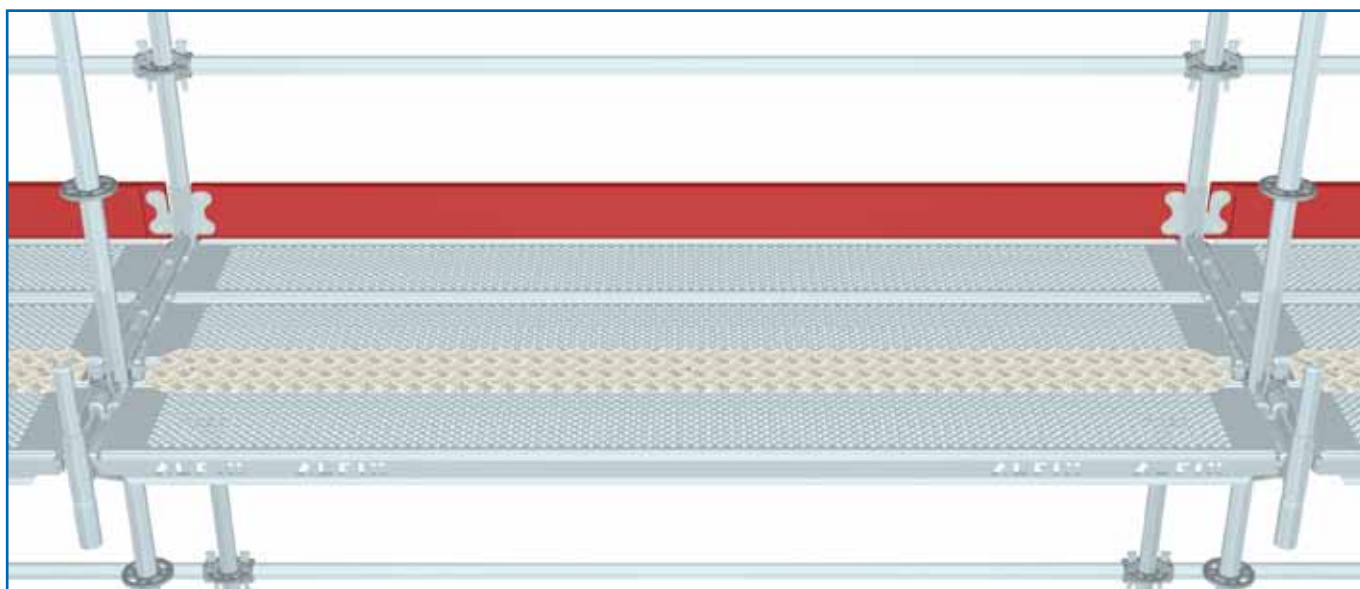

Application example: Gap cover

### Module brackets

- steel, zinc-plated
- for broadening or extending the scaffold inwards and outwards
- with U-profile for system decks
- deck retainer, see pages 6/7

### Module bracket brace

- steel, zinc-plated
- for supporting module brackets
- for single-edge installation on the perforated disc

### Bracket RE

- steel, zinc-plated
- for bracket broadening when RE decks are used

### Bracket with tube ledger fixture

- steel, zinc-plated
- for extending building recesses on deck level or at intermediate heights

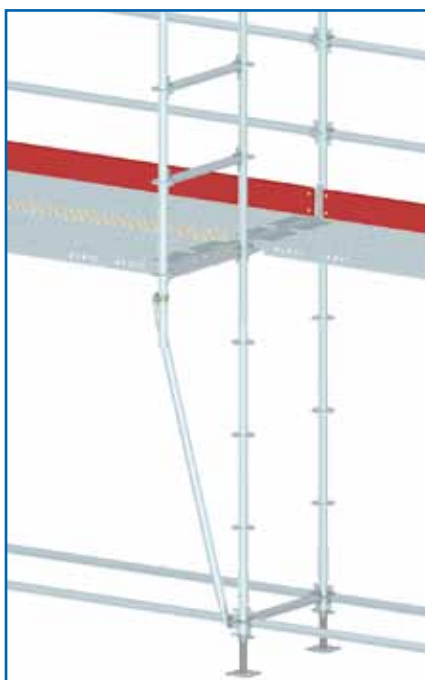

1a) Module bracket 0.28 m



1b) Module bracket 0.36 m



1c) Module bracket 0.39 m



1d) Module bracket 0.73 m



2) Module bracket brace  
• for supporting bracket 0.73 m



3a) Bracket RE 0.39 m

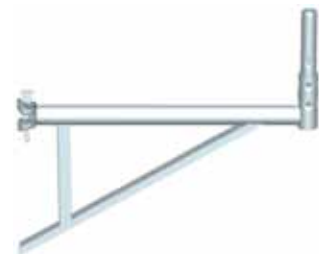

3b) Bracket RE 0.73 m



4a) Bracket with tube ledger fixture and wedge connection, 0.36 m



4b) Bracket with tube ledger fixture and wedge connection, 0.73 m

Application example: **Bracket brace** for creating projections as an alternative to brackets

Fig.	Designation	Dimensions L/HxW [m]	Weight [kg]	Article number	Price [€]
1a	<b>Module bracket</b>	0.28	3.0	40 10 011	26.25
1b	steel	0.36	3.9	40 10 000	24.90
1c	hot-dip galvanised	0.39	3.9	40 10 008	24.85
1d		0.73	6.4	40 10 006	29.45
		1.09	12.0	40 10 012	61.65
2	<b>Module bracket brace</b>	2.05	7.5	40 10 205	38.25
3a	<b>Bracket RE</b>	0.39	3.8	40 10 009	33.15
3b	steel	0.73	5.8	40 10 013	40.50
	hot-dip galvanised				
4a	<b>Bracket with tube ledger fixture</b>	0.36	6.0	40 10 030	40.95
4b	steel	0.73	7.5	40 10 035	43.30
	hot-dip galvanised				

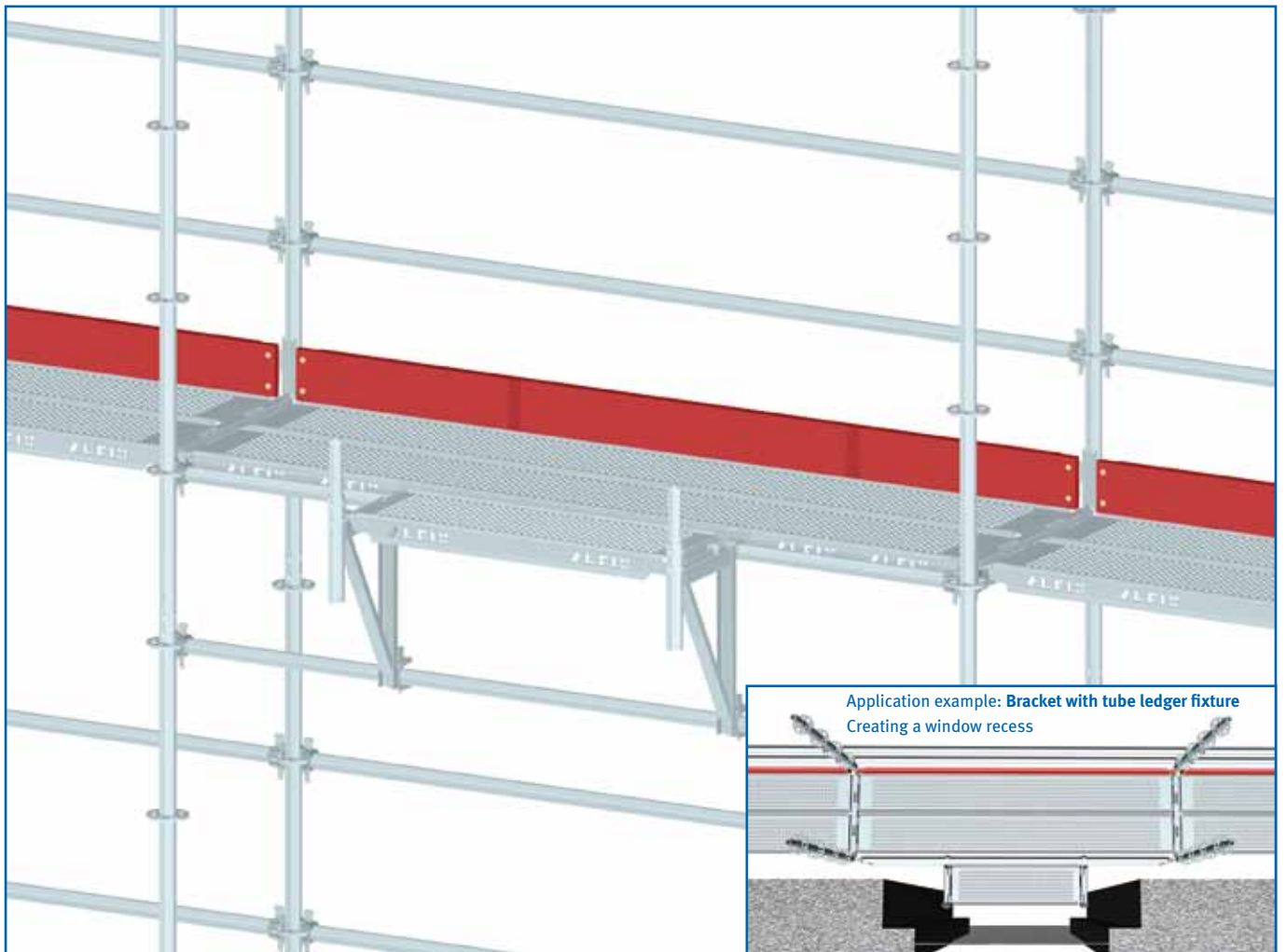

Application example: **Bracket RE**

### Module lattice girder

- steel, zinc-plated
- available in all system lengths from 1.57 m to 7.71 m
- available in tube profile (for decks with circular tube support) and U-profile designs
- suitable for bridging a distance or for surface scaffoldings
- for direct connection to perforated disc by means of the wedge head
- installation of lattice girder according to approval Z-8.22-906
- deviating therefrom, applications with module lattice girders are to be proven through object-related calculations
- see also load capacity table
- module lattice girder with welded-on spigot fitting, on request
- applicable fastening bolts, see section "Accessories" on pages 30/31

### Module lattice girder cross brace

- steel, zinc-plated
- for bridging distances within the façade scaffolding module
- safeguarding against lifting with fastening bolts
- deck retainer see page 6/7
- flexible alternative to lattice girders with welded-on spigot fitting

### Spigot fitting

- steel, zinc-plated
- 4) • to be attached on U-profiles or tubes
    - safeguarding against lifting with fastening bolts
  - 5) • suitable on tube ledgers or module lattice girders with top boom for variable vertical upright arrangement

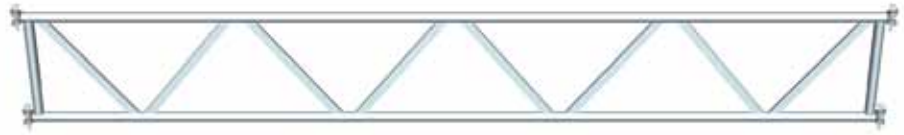

1) Module lattice girder, steel, with 4 wedge heads

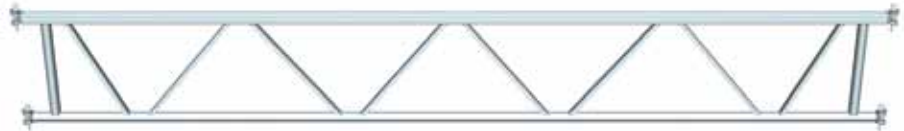

2) Module U-lattice girder, steel, with 4 wedge heads



3) Module lattice girder cross brace



4) Spigot fitting for U-bridging ledger and tube support



5a) Spigot fitting for lattice girder, with coupler



5b) Spigot fitting for lattice girder with wedge connection (double bead coupling)

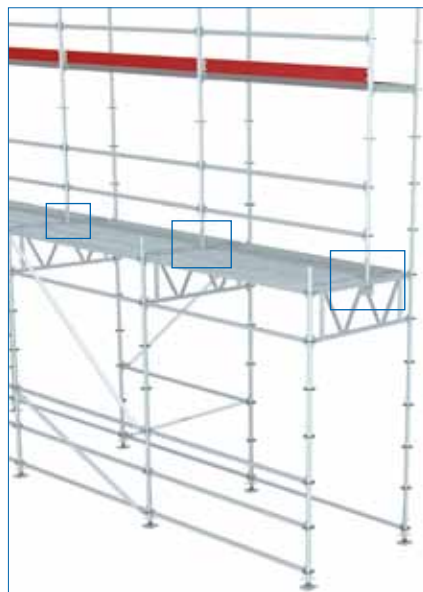

Application example: **Spigot fitting** for U-bridging ledger for erecting pedestrian underpasses in varying widths

Fig.	Designation	Dimensions L/HxW [m]	Weight [kg]	Article number	Price [€]
1	<b>Module lattice girder</b> with 4 wedge heads Top and bottom boom, steel tube 48.3 mm steel, hot-dip galvanised	5.14	50.0	40 70 515	<b>201.60</b>
		6.21	62.5	40 70 622	<b>236.35</b>
		7.71	77.1	40 70 772	<b>302.95</b>
2	<b>Module U-lattice girder steel</b> with 4 wedge heads for fixing system decks Top boom, U-profile Bottom boom, steel tube 48.3 mm steel, hot-dip galvanised	3.07	31.2	40 71 307	<b>153.75</b>
		4.14	40.5	40 71 414	<b>188.75</b>
		5.14	50.9	40 71 514	<b>227.70</b>
		6.14	61.1	40 71 614	<b>247.70</b>
		7.71	75.9	40 71 771	<b>321.25</b>
3	<b>Module lattice girder cross brace</b> suitable for module lattice girders and module U-lattice girders steel, hot-dip galvanised	0.73	7.1	40 73 073	<b>41.35</b>
		1.09	8.2	40 73 109	<b>55.00</b>
4	<b>Spigot fitting for U-bridging ledger and tube support</b> steel, hot-dip galvanised	0.4	2.1	4151002	<b>19.80</b>
<b>Spigot fitting for lattice girder</b> steel, hot-dip galvanised					
5a	with coupler	0.3	1.6	41 51 001	<b>17.05</b>
5b	with wedge connection	0.3	1.5	41 51 007	<b>19.35</b>

Module lattice girder: deck partitioning				
1.57	4 x 0.32 m	1 x 0.19 m	4.14	12 x 0.32 m 1 x 0.19 m
2.07	6 x 0.32 m		5.14	15 x 0.32 m 1 x 0.19 m
2.57	7 x 0.32 m	1 x 0.19 m	6.14	18 x 0.32 m 1 x 0.19 m
3.07	9 x 0.32 m		7.71	23 x 0.32 m 1 x 0.19 m

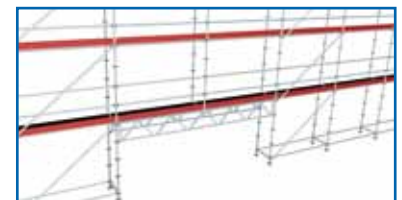
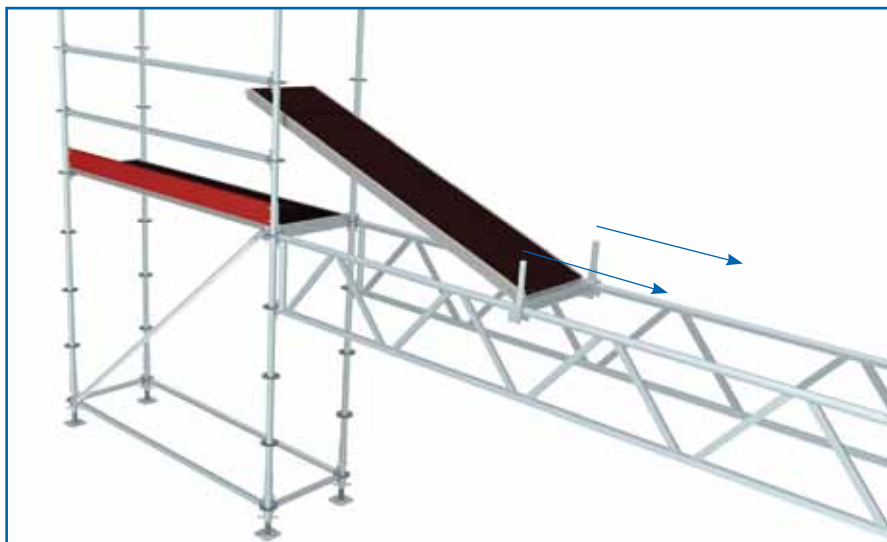

**Application example: Lattice girder**  
Installation of decks is carried out using the movable lattice girder cross brace. Thus, a fail-safe built-in to the decks is possible, since they can be positioned on lattice girders from the already erected part of the scaffold.

**Stair stringer**

- steel, zinc-plated
- with U- or flat steel fixture for system decks
- connection with halfcoupler for loads of max. 200 kg/m<sup>2</sup> or with wedge heads for loads of max. 500 kg/m<sup>2</sup>
- available in installation height 1.00 m for bay length 1.57 m and 2.00 m for bay length 2.57 m

**Childproof guardrail**

- steel, zinc-plated
- suitable for installation in a stairway tower up to 500 kg
- with vertical bars
- on request, also available for any other system dimensions
- suitable for escape stair towers or similar applications in public areas

**Module security door**

- steel, zinc-plated
- with integrated locking mechanism (self-locking)
- for securing accesses, e.g. in stair towers

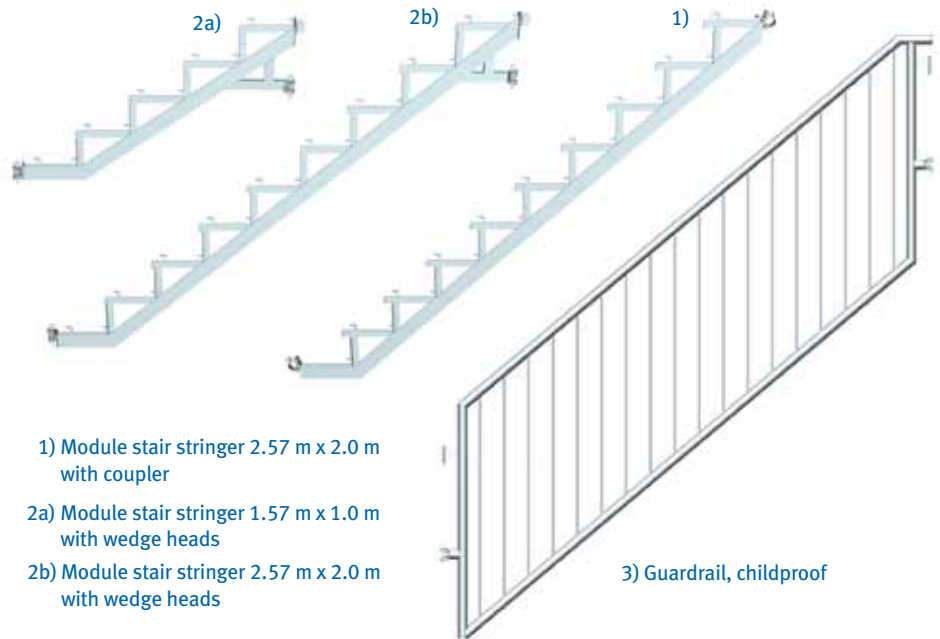

- 1) Module stair stringer 2.57 m x 2.0 m with coupler
- 2a) Module stair stringer 1.57 m x 1.0 m with wedge heads
- 2b) Module stair stringer 2.57 m x 2.0 m with wedge heads

3) Guardrail, childproof

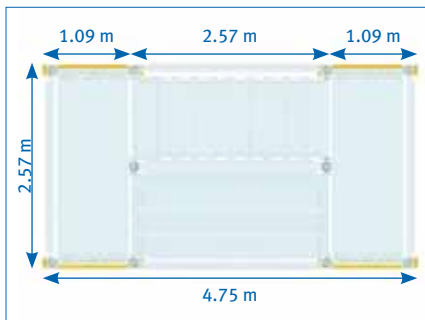

**A**

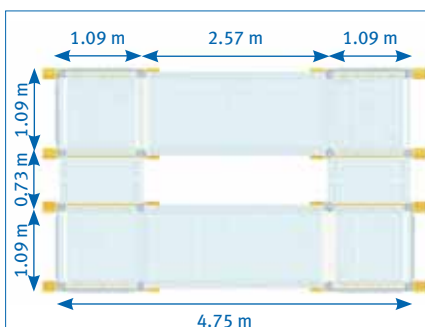

**B**



**Construction site stair tower 200 kg (Figure A)**

- 10-upright stair tower with stair stringers for fixing system decks (e.g. steel decks)
- 9 treads per 22 cm / 10 decks per stairway
- stair width max. 1.09 m
- safe load max. 2.0 kN/m<sup>2</sup>



**Escape stair tower 500 kg (Figure B)**

- 16-upright stair tower with stair stringers for fixing system decks (e.g. steel decks)
- varying stair width, depending on particular application
- 9 treads per 22 cm / 9 decks per stairway
- safe load max. 5.0 kN/m<sup>2</sup>

Fig.	Designation	Dimensions L/HxW [m]	Weight [kg]	Article number	Price [€]
1	<b>Module stair stringer</b> with coupler; max. load 200 kg/m <sup>2</sup> (load class 3)	1.57 x 1.00	17.1	41 07 054	<b>192.35</b>
		2.57 x 2.00	28.1	41 07 060	<b>245.80</b>
2a	<b>Module stair stringer</b> with wedge heads; max. load 500 kg/m <sup>2</sup> (load class 5)	1.57 x 1.00	16.1	41 07 053	<b>192.45</b>
2b		2.57 x 2.00	27.3	41 07 061	<b>245.80</b>
3	<b>Guardrail</b> childproof	1.57 x 1.00	26.2	41 36 102	<b>223.75</b>
		2.57 x 2.00	42.8	41 36 202	<b>278.05</b>
4	<b>Childproof guardrail</b>	0.73 x 1.10	14.3	41 40 073	<b>108.65</b>
		1.09 x 1.10	18.5	41 40 109	<b>133.50</b>
		1.57 x 1.10	24.3	41 40 157	<b>166.70</b>
		2.07 x 1.10	29.8	41 40 207	<b>199.80</b>
		2.57 x 1.10	35.9	41 40 257	<b>232.95</b>



4) Childproof Guardrail



5) Gap ledger



6) Module security door

5	<b>Gap ledger</b>	0.73	5.5	40 20 077	<b>56.45</b>
		1.09	6.8	40 20 113	<b>62.65</b>
		1.57	9.3	40 20 161	<b>68.15</b>
		2.07	10.5	40 20 211	<b>78.30</b>
		2.57	12.3	40 20 261	<b>87.50</b>
		3.07	14.1	40 20 311	<b>96.70</b>
6	<b>Module security door</b>	0.73	11.8	40 77 073	<b>78.30</b>
		1.09	13.8	40 77 109	<b>81.90</b>



Application example: **Module security door**



Application example: **Gap ledger (1) and Gap cover (2)** (gap cover, see page 18/19)

← Application example: **16-upright stair tower**, starting height: 1 m

**Stair stringer**

- steel, zinc-plated
- with U-fixture for system decks
- connection with wedge heads for loads of max. 750 kg/m<sup>2</sup>
- available in installation height 1.00 m and 1.50 m for bay length 2.57 m

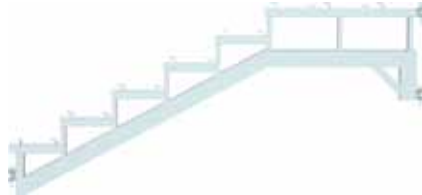

1) Module stair stringer 2.57 m x 1.00 m



2) Guardrail 2.57 m x 1.00 m

**Childproof guardrail**

- steel, zinc-plated
- suitable for installation in a stairway tower up to 750 kg
- with vertical bars
- on request, also available for any other system dimensions
- suitable for escape stair towers or similar applications in public areas



1) Module stair stringer 2.57 m x 1.50 m

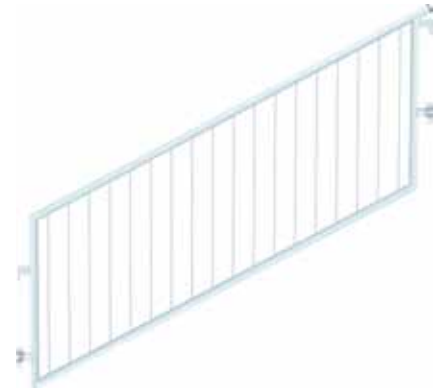

2) Guardrail 2.57 m x 1.50 m

**Gap cover**

- as an alternative to deck retainer
- designed for double upright or as a T-profile for covering the mounting claws of the decks and/or the U-profile at continuous platforms
- chequer plates, aluminium
- for covering gaps between deck levels
- safeguarding against lifting with clamping coupler (universal design)

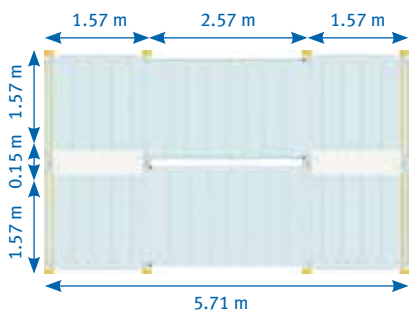

3) Gap cover for double upright



4) Gap cover, T-profile



5) Clamping coupler (universal design)



**Escape stair tower 500 kg or 750 kg**

- 16-upright stair tower with stair stringers for fixing system decks (e.g. steel decks)
- varying stair width, up to 1.57 m (statically induced)
- 9 treads per 17 cm / 8 decks per stairway
- safe load max. 7.5 kN/m<sup>2</sup>

Fig.	Designation	Dimensions L/HxW [m]	Weight [kg]	Article number	Price [€]
1	<b>Module stair stringer</b> with wedge heads; max. load 750 kg/m <sup>2</sup>	2.57 x 1.00	45.4	41 07 063	<b>261.65</b>
		2.57 x 1.50	44.4	41 07 065	<b>294.65</b>
2	<b>Guardrail</b> childproof	2.57 x 1.00	40.1	41 36 162	<b>217.85</b>
		2.57 x 1.50	41.6	41 36 182	<b>269.75</b>
3	<b>Gap cover for double upright</b> chequer plates, aluminium	1.09 x 0.40	5.6	40 33 109	<b>50.95</b>
		1.57 x 0.40	8.5	40 33 157	<b>44.50</b>
		2.07 x 0.40	11.5	40 33 207	<b>58.70</b>
4	<b>Gap cover, T-profile</b> chequer plates, aluminium	1.09 x 0.19	2.3	40 34 109	<b>31.35</b>
		1.57 x 0.19	3.5	40 34 157	<b>38.05</b>
		2.07 x 0.19	4.7	40 34 207	<b>44.70</b>
5	<b>Clamping coupler (universal design)</b>	0.20	1.1	13 17 019	<b>11.25</b>



Installation instruction for stair stringer 750 kg

It is recommended to use a suitable flat steel for driving the wedge into the module connector through the opening (10 x 35 mm) provided in the stair stringer. Flat steels are available on request.

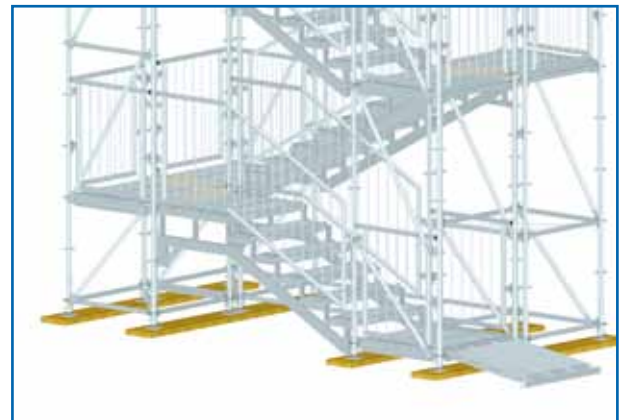

Application example: **Stairway tower** with starting height 1 m (ground adjustment through system decks and starter transoms)

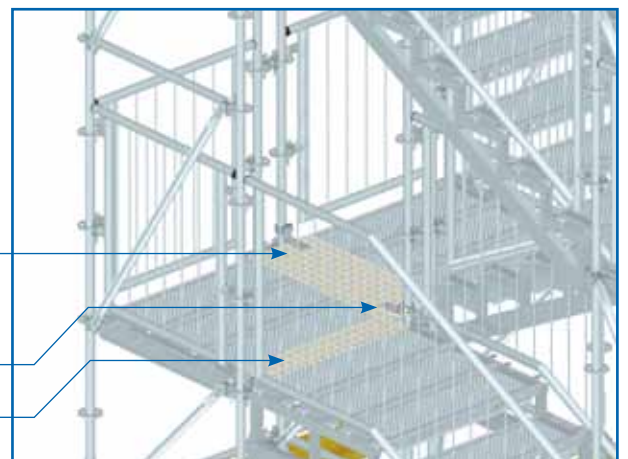

Application example: **Gap cover for double upright** and safeguarding against lifting with **Clamping coupler (universal design)** and **Gap cover** (see pages 18/19)

**Aluminium stairway**

- with system fixture
- 10 treads per 20 cm
- load max. 2 kN/m<sup>2</sup>
- suitable for platform stair tower applications

**Handrail, double**

- steel, zinc-plated
- with double bead coupler (special wedge coupler) for fixing on tube ledgers or hand-rail/guardrail fasteners



1) Aluminium stairway

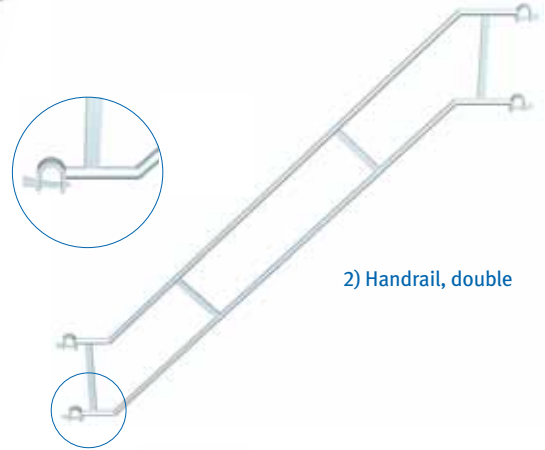

2) Handrail, double

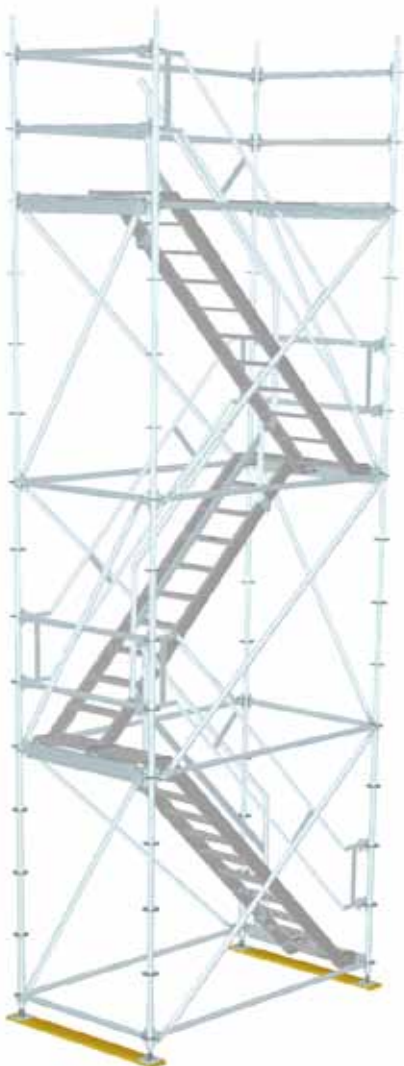

3) Handrail fastener for double handrail



5) Aluminium storey ladder



6) Steel storey ladder



4) Inner guardrail for aluminium stairs

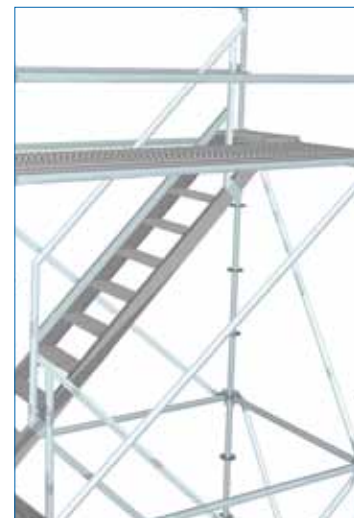

Application example: **Inner guardrail for aluminium stairway**

Application example: **Alternating stair tower**  
For this application, the use of an inner guardrail is mandatory.

Fig.	Designation	Dimensions L/HxW [m]	Weight [kg]	Article number	Price [€]
1	<b>Aluminium stairway</b> max. load 200 kg/m <sup>2</sup> (load class 3)	2.57 x 0.60	21.8	11 30 257	<b>311.70</b>
		3.07 x 0.60	26.5	11 30 307	<b>380.00</b>
2	<b>Handrail double</b> steel, hot-dip galvanised	2.57 x 2.00	16.4	41 36 200	<b>89.30</b>
		3.07 x 2.00	18.5	41 36 205	<b>98.55</b>
3	<b>Handrail fastener</b> steel, hot-dip galvanised		0.80	41 36 300	<b>11.55</b>
4	<b>Inner guardrail for aluminium stairs, height 2.00 m</b> steel, hot-dip galvanised	2.57 / 3.07	21.1	41 28 200	<b>86.60</b>
5	<b>Storey ladder, aluminium</b> for storey height 2.00 m	2.00 x 0.40	3.7	11 32 001	<b>47.95</b>
6	<b>Storey ladder, steel</b> hot-dip galvanised; for storey height 2.00 m	2.00 x 0.40	8.1	11 42 000	<b>36.85</b>



**Platform stair tower**

- add-on or integrated access ladder for safe climbing
- safe load max. 2.0 kN/m<sup>2</sup>



Application example:  
**Fixing of guardrail** using the  
double bead coupler on handrail  
fastener

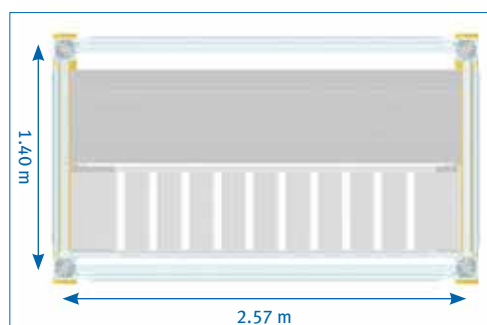

Platform stair tower, top view

**Couplers**

- for tubes 48.3 mm
- The used couplers comply with EN 74 and possess the respective manufacturer approval.

**Spacing tube**

- steel tubing, zinc plated,
- 48.3 x 3.2 mm
- spacing tubes must be used with 2 standard couplers

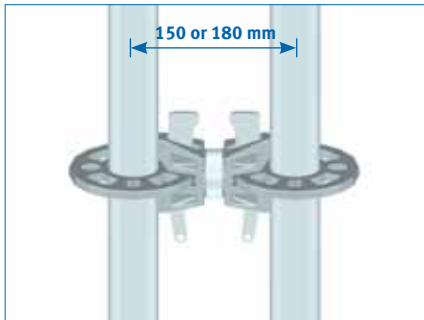

Application example: **Distance coupling**

**Spigot fitting (universal design)**

- consisting of 2 half-shells and a screw
- for connecting tubes subject to impact stress
- spread through the screw



9) Spigot fitting (universal design), clampable



10) Coupler for square-shaped timber



1) Swivel coupler



2) Standard coupler



3a) Wedge head coupler, fixed



3b) Wedge head coupler, turnable



4) Distance coupling



5) Claw coupler



6) Halfcoupler



7) Tension coupler



8) Spigot fitting for tension coupler



11) Screw, hexagon head  
M 14 x 65, DIN 931 8.8



12) Cap nut  
M14, DIN 1587



13) Spacing tube



14) Quick-release anchor



15) Steel tube



16) Aluminium tube

Fig.	Designation	Dimensions L/HxW [m]	Weight [kg]	Article number	Price [€]
1	<b>Swivel coupler</b>	SW 19	1.0	13 03 019	<b>6.30</b>
		SW 22	1.0	13 03 022	<b>6.30</b>
2	<b>Standard coupler</b>	SW 19	1.0	13 01 019	<b>5.70</b>
		SW 22	1.0	13 01 022	<b>5.70</b>
<b>Wedge head coupler</b>					
3a	fixed		1.0	41 50 000	<b>15.25</b>
3b	turnable		1.0	41 50 001	<b>17.05</b>
4	<b>Distance coupling fixed</b>	0.15	1.1	41 50 003	<b>15.60</b>
		0.18	1.2	41 50 002	<b>15.60</b>
5	<b>Claw coupler</b>	SW 19	0.9	13 10 019	<b>9.80</b>
6	<b>Halfcoupler</b>	SW 19	0.6	13 02 019	<b>3.00</b>
7	<b>Tension coupler</b> with collar nuts, for tubes Ø 48.3 mm	SW 19	1.4	13 07 019	<b>8.35</b>
8	<b>Spigot fitting</b> for tension coupler	SW 19	1.0	13 08 000	<b>4.25</b>
9	<b>Spigot fitting (universal design)</b> , clampable, consisting of 2 half-shells and a screw	0.24	1.7	13 08 001	<b>9.10</b>
10	<b>Coupler for square-shaped timber</b> with metal sheet (HxWxD of sheeting: 100 x 220 x 86 mm)	SW 19	1.8	33 81 019	<b>15.85</b>
11	<b>Screw</b> hexagon head M 14 x 65 DIN 931 8.8 zinc-plated with cap nut (item 12) to be used as fastening bolt		0.1	14 51 100	<b>0.45</b>
12	<b>Cap nut</b> DIN 1587- M14 steel, zinc-plated with hexagon screw (item 11) to be used as fastening bolt		0.04	73 02 003	<b>1.10</b>
13	<b>Spacing tube</b>	0.40	1.5	13 61 040	<b>7.95</b>
		1.00	3.3	13 61 100	<b>12.45</b>
		1.30	4.2	13 61 130	<b>13.65</b>
		1.50	4.8	13 61 150	<b>16.85</b>
14	<b>Quick-release anchor</b>	0.60	2.3	13 62 065	<b>10.65</b>
<b>Scaffold tubing</b>					
15	steel Ø 48.3 x 3.25 mm	6.00	21.3	13 50 600	<b>52.20</b>
16	aluminium Ø 48.3 x 4.00 mm	6.00	9.0	13 41 600	<b>66.85</b>
		fixed length (up to 6 m) steel	running meters (per m) 3.5	13 50 ***	<b>9.75</b>
		fixed length (up to 6 m) aluminium	running meters (per m) 1.5	13 40 ***	<b>11.50</b>

\*\*\* tube length in cm

In the standard version, the scaffold may be used as a working scaffold for load classes  $\leq 3$  with system width  $b=0.732$  m and bay width  $l=3.07$  m, or for load classes  $\leq 4$  with system width  $b=1.09$  m and bay width  $l=2.57$  m according to DIN EN 12811-1:2004-03, and as a safety and roof safety scaffold acc. to DIN 4420-1:2004-03.

The upper horizontal level (scaffold layer) must not exceed 24 m, plus spindle (jack) extension length, above ground level. According to the requirements of DIN EN 12811-1:2004-03, Section 6.2.9.2, in the standard version, the scaffolding system is designed for working operations in one scaffolding layer in front of an "open" façade (percentage of openings = 60 percent) and in front of closed façades.

Without any further proofs, the standard version must only be used if the loads acting within the bays do not exceed the respective live loads according to DIN EN 12811-1:2004-03, Table 3.

For the standard version of "ALFIX Modul PLUS II" scaffolding system, the following designations according to DIN EN 12810-1:2004-03 shall be used:

Scaffold EN 12810-3D-SW06/307-H2-A-LA

Scaffold EN 12810-4D-SW09/257-H2-A-LA

When erecting and dismantling the Modul Plus II scaffold, the provisions of the employer's liability insurance association for construction sites, the accident prevention regulations for construction works (BGV 22, previously VBG 37) and the instructions and requirements of DIN 4420 or EN 12811 must be observed.

In an object-related instruction for erection and use and based on a risk and hazard assessment, the employer is entitled to decide in which way

### Load-bearing capacity: ALFIX Modul Plus II Scaffolding connector

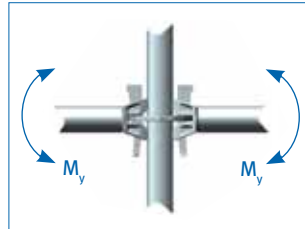

Bending moment  $M_{y,R,d} = \pm 104$  kNcm

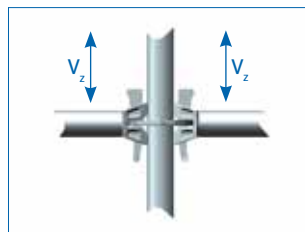

Vertical cross-load  $V_{z,R,d} = \pm 35$  kN

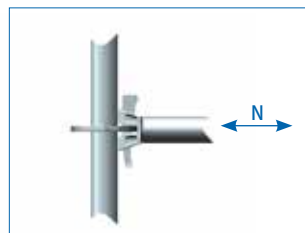

Normal force  $N_{R,d} = \pm 36$  kN

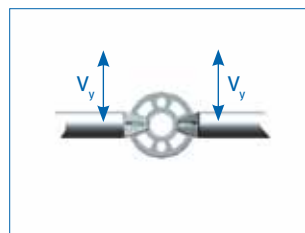

Horizontal cross-load  $V_{y,R,d} = \pm 16$  kN

### Load-bearing capacity: ALBLITZ Modul Scaffolding connector

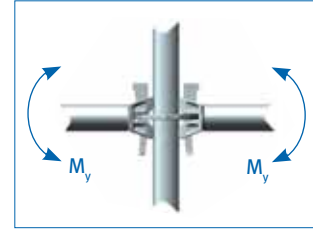

Bending moment  $M_{y,R,d} = \pm 101$  kNcm

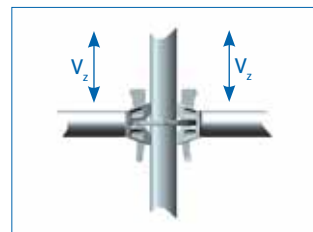

Vertical cross-load  $V_{z,R,d} = \pm 26$  kN

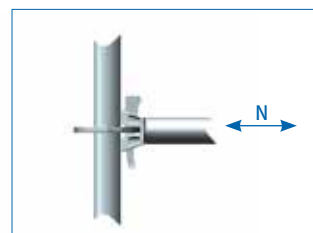

Normal force  $N_{R,d} = \pm 31$  kN

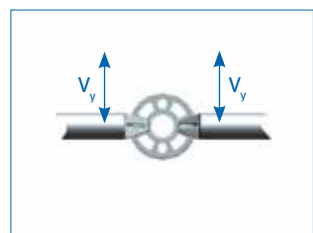

Horizontal cross-load  $V_{y,R,d} = \pm 10$  kN

the protection against falling must be ensured in an adequate manner under the observance of the respective industrial safety regulations.

Possible protective actions are technical measures, personal protective equipment (PPE) against falling, and special instructions. As a technical protective measure, ALFIX provides two variants of "advancing guardrails", which are documen-

ted separately or by means of the manuals provided by the "advancing guardrail" manufacturers.

If the result of risk assessment requires the use of PPE, suitable attachment points on scaffold must be used, such as, for example, the idle outer service aperture of connecting disc or the outer vertical upright above the deckings (max. 1 m above standing height).

Vertical upright: permissible <sup>1</sup> upright load (compressive load) or tensile load-bearing capacity at screwed-in spigot						Tensile load
Buckling length [m]	1.0	1.5	2.0	3.0	4.0	2x2 M10 8.8
permissible load N [kN]	64.9	43.7	28.4	14.0	8.2	42.7

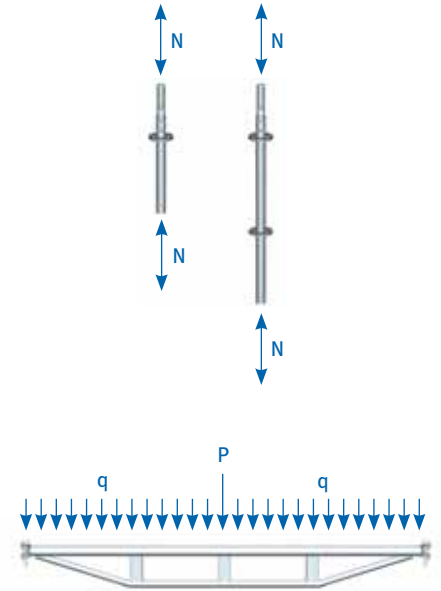

U-ledger: permissible <sup>1</sup> cross-loads						
	Ledger	Ledger, reinforced	U-bridging ledger			
Length L [m]	0.73	1.09	1.57	2.07	2.57	3.07
permissible uniformly distributed load q [kN/m]	17.00	17.50	12.50	9.50	6.70	5.00
permissible single load P [kN] in centre	6.00	8.90	11.10	8.20	7.50	6.00

Tube ledger: permissible <sup>1</sup> cross-loads						
	Ledger	Ledger, reinforced	R-bridging ledger			
Length L [m]	0.73	1.09	1.57	2.07	2.57	3.07
permissible uniformly distributed load q [kN/m]	21.80	16.80	16.60	10.40	6.60	4.70
permissible single load P [kN] in centre	7.90	14.20	14.20	8.70	5.60	4.50

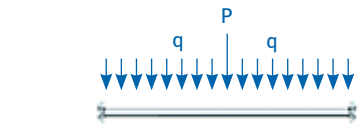

Tube ledger: permissible <sup>1</sup> standard load (permissible Z=24 kN)						
Bay length [m]	0.73	1.09	1.57	2.07	2.57	3.07
Permissible compressive force D [kN]	24.00	24.00	24.00	24.00	18.40	13.40





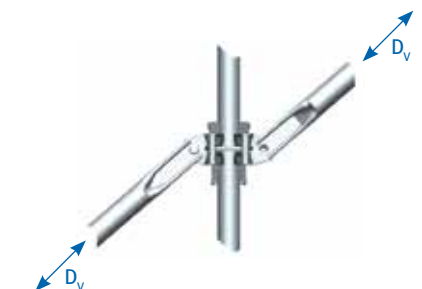





Vertical diagonal brace: permissible <sup>1</sup> normal force, bay height: 2.0 m						
Bay length [m]	0.73	1.09	1.57	2.07	2.57	3.07
Permissible compressive force D [kN]	14.70	14.30	12.30	10.30	8.50	6.90
Permissible tensile force D [kN]	14.70	15.20	15.20	15.20	15.20	15.20



1: safe load determined using  $\gamma_M=1.1$  and  $\gamma_F=1.5$

### Load classes of scaffolding decks

Scaffolding decks	Designation	Bay width l (m)	Safety and roof safety scaffolding applications	Usage in load class	
	Steel plank 0.32 m	≤ 2.07	permissible	6	
		2.57	permissible	5	
		3.07	permissible	4	
		4.14	permissible	3	
	Solid wooden deck 0.32 m	≤ 1.57	permissible	6	
		2.07	permissible	5	
		2.57	permissible	4	
		3.07	permissible	3	
	Solid aluminium deck 0.32 m	≤ 2.07	permissible	6	
2.57		permissible	5		
3.07		permissible	4		
4.14		-	3		
Solid aluminium deck 0.60 m	≤ 2.07	permissible	6		
	2.57	permissible	5		
	3.07	permissible	4		
Aluminium frame platform 0.60 m with water-resitant screen-printed plywood surface	≤ 3.07	permissible	3		
Aluminium frame platform 0.60 m with hatch-type access and storey ladder	≤ 3.07	permissible	3		
Solid aluminium frame platform 0.60 m with hatch-type access and storey ladder	2.57	permissible	4		
	3.07	permissible	3		
Aluminium frame platform 0.60 m with hatch-type access, without ladder	≤ 3.07	permissible	3		

### Parameters of horizontal diagonal braces (extract from the approval number Z-8.22-906)

Horizontal diagonal braces	Bay length (m)	Bay width (m)	$N_{H,R,d}$ (kN)	
	2.07	0.73	3.03	
	2.57	0.73	3.00	
	3.07	1.09	2.95	

### Cross-section values of base jacks

Base jack	The equivalent cross-section values of spindle to be used for stress analysis and deformation calculations according to DIN 4425 are to be assumed as follows:		
	$A = A_s$	= 3.52 cm <sup>2</sup>	
	$I$	= 4.00 cm <sup>4</sup>	
	$W_{et}$	= 2.68 cm <sup>3</sup>	
$W_{pl}$	= 1.25 x 2.68 = 3.35 cm <sup>3</sup>		

Working loads on scaffold layers						
Scaffold layers	Load class	Uniformly distributed load $q_1$ in kN/m <sup>2</sup>	Load concentrated on a 500 mm x 500 mm area, $F_1$ in kN	Load concentrated on a 200 mm x 200 mm area, $F_2$ in kN	Partial area load	
					$q_2$ kN/m <sup>2</sup>	Partial area factor $a_p$ (%)
Scaffold layers	1	0.75	1.50	1.00	-	-
	2	1.50	1.50	1.00	-	-
	3	2.00	1.50	1.00	-	-
	4	3.00	3.00	1.00	5.00	0.4
	5	4.50	3.00	1.00	7.50	0.4
	6	6.00	3.00	1.00	10.00	0.5

Clearance classes			
Scaffold layers	Class	Clearance	
		between scaffold layers $h_3$	between scaffold layers and transoms or scaffold retainers $h_{1a}$ and $h_{1b}$
Scaffold layers	H <sub>1</sub>	$h_3 \geq 1.90$ m	$1.75 \text{ m} \leq h_{1a} \leq 1.90 \text{ m}$ $1.75 \text{ m} \leq h_{1b} \leq 1.90 \text{ m}$
	H <sub>2</sub>	$h_2 \geq 1.90$ m	$h_{1a} \geq 1.90$ m $h_{1b} \geq 1.90$ m

Width classes		
Scaffold layers	Width class	w in m
Scaffold layers	W06	$0.6 \leq w \leq 0.9$
	W09	$0.9 \leq w \leq 1.2$
	W12	$1.2 \leq w \leq 1.5$
	W15	$1.5 \leq w \leq 1.8$
	W18	$1.8 \leq w \leq 2.1$
	W21	$2.1 \leq w \leq 2.4$
	W24	$2.4 \leq w$

**Clear heights and widths of scaffold layers**

- $b$  open passageway clearance, 500 mm is the minimum requirement, and (c - 250 mm)
- $c$  clear spacing between posts
- $h_{1a}, h_{1b}$  clear width between scaffold layers and transoms or scaffold retainers
- $h_2$  clear shoulder height
- $h_3$  clear height between scaffold layers
- $p$  clear width in the head area; 300 mm is the minimum requirement, and (c - 450 mm)
- $w$  width of scaffold layers

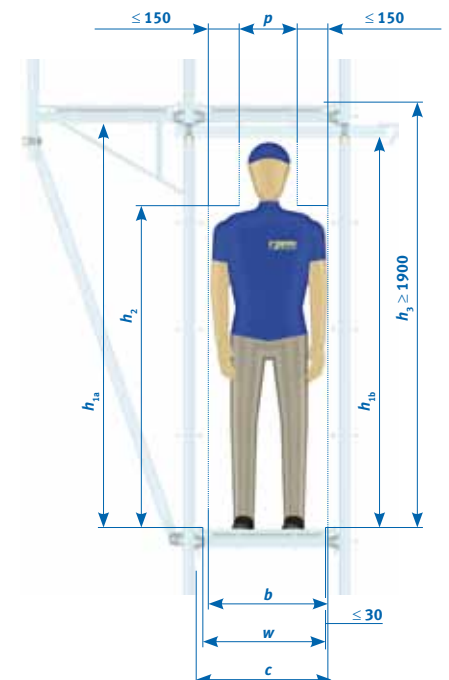

**Designation of a scaffolding system according to EN 12810-1 (example)**

Scaffold according to EN 12810 - 4 D - SW09/257 - H2 - A - LA	
Scaffold according to EN 12810	Frame scaffold (modular scaffold) according to DIN EN 12810-1
4	Load class 4 (see Table 3 DIN EN 12811-1)
D	Vertical drop tests on deck surface (D = calculated with drop test, N = without drop test)
SW09/257	Width class (see Table 1 DIN EN 12811-1) here: between 0.90 m and 1.20 m/bay length 2.75 m
H2	Headroom class (see Table 2 DIN EN 12811-1)
A	Without sheeting (A = without sheeting, B = with sheeting)
LA	With ladder (LA = ladder, ST = stairway, LS = with both)

ALFIX Systemtechnik GmbH  
Dorfwiesenweg 13  
D-63828 Kleinkahl-Edelbach  
Phone +49 (0) 6024 / 6731-0  
Fax +49 (0) 6024 / 2064  
eMail: [vertrieb@alfix.de](mailto:vertrieb@alfix.de)

ALFIX GmbH Rüst- und Lagertechnik  
Langhennersdorfer Straße 15  
D-09603 Großschirma  
Phone +49 (0) 37328 / 800-0  
Fax +49 (0) 37328 / 800-80  
eMail: [info@alfix.de](mailto:info@alfix.de)

#### **Sale of:**

- **Work & safety scaffoldings**
- **Mobile scaffold towers**
- **Stairway towers**
- **Construction equipment**
- **Brickwork platforms**
- **Roofing systems**
- **Stages and platforms**
- **Chimney scaffolds**
- **Shelves**
- **Accessories**

#### **Lease of:**

- **Work & safety scaffoldings**
- **Mobile scaffold towers**
- **Roofing systems**
- **Stages and platforms**
- **Chimney scaffolds**

**Manufacturer's agent:**

---